

 **pastorelli**

2015

Legenda

Key . Légende . Legende . Leyenda .



SERIE REALIZZATA CON TECNOLOGIA DIGITALE

Series produced with Digital Technology . Série réalisée avec technologie digitale
Serie mit Digital Druck Technologie geschaffen . Colección realizada por tecnología digital

CODICI FASCE DI PREZZO

Prices band codes . Codes des séries de prix . Kodes Preisgruppen . Códigos segmentos de precio

10

Prezzo paletta completa per m²

Price for full palettes (per m²) . Prix pour palette complète au m²
Preisgruppe für ganze palette, je m² . Segmento de precio por pallet completo por m².

8

Prezzo paletta parziale inteso al m²

Price for partial palettes (per m²) . Prix pour palette partielle au m²
Preisgruppe für unvollständige palette, je m² . Segmento de precio por pallet parcial por m².

22

Prezzo inteso al metro lineare.

Price (per linear metre) . Prix au mètre linéaire.
Preisgruppe, je laufender meter . Segmento de precio por metro lineal.

15

Numero fascia di prezzo inteso al pezzo o alla composizione.

Price band number per piece or set . Numéro de la série de prix par pièce ou par composition.
Nummer preisgruppe, je stück oder komposition . Número segmento de precio por cada pieza o por composición.

STRUTTURE - FINITURE

Structures - Finishing . Structures - Finissages . Strukturen - Nacharbeiten . Estructuras - Acabados

nat. **Naturale** | Unpolished | Matt | Mat | Natural

nat. rett. **Naturale - Rettificato** | Unpolished - Rectified | Mat - Rectifiés | Matt - Rektifiziert | Natural - Rectificado

lap. rett. **Lappato - Rettificato** | Lapped - Rectified | Lissé - Rectifiés | Geläpft - Rektifiziert | Alisado - Rectificado

IMBALLI

Packaging . Emballages . Verpackungen . Embalajes



NUMERO DI PEZZI PER SCATOLA

Number of pieces per box . Nombre de pièces par boîte
Anzahl der Stücke je Karton . Numero de piezas por cada caja

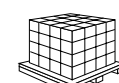

NUMERO DI SCATOLE PER PALLET

Number of boxes per pallet . Nombre de boîtes par palette
Anzahl der Kartons je Palette . Numero de cajas por cada pallet

Sommario

Sommary . Sommaire . Verzeichnis . Sumario .



Stone

8	Ayers Rock
12	Atelier
20	Duomo
22	Himalaya
26	Lithos
30	Loft
32	Manhattan
36	Marfil
38	Milano City
48	Pierre Royale
54	Quarz Design
64	Shade
74	Tailormade
84	V.360
94	Villa Imperiale

20MM

20 mm

112	Atelier 20 mm
114	Milano City 20 mm
116	Quarz Design 20 mm
118	Shade 20 mm
120	V.360 20 mm
121	Delta 20 mm
122	Madera 20 mm



Le Porcellane Smaltate

126	Amalfi
128	Antiche Doghe
132	Country Life
136	Elite
148	Madera
154	Marmi Antichi
160	Patina
166	Terre Senesi
168	Walnut



Habitat

174	Borghi d'Italia
176	Tailormade



Progetto

182	Tradizionale
-----	--------------

WallPaper

Wall paper

186	Elite
188	Shade Warm
190	Shade Cold
192	Atelier Warm
194	Atelier Cold
196	Milano City Warm
198	Milano City Cold
200	Tailormade
202	Patina Warm
204	Patina White
206	Manhattan
208	Caratteristiche principali <i>Main technical features</i>
208	La posa <i>Laying scheme</i>

INFORMAZIONI TECNICHE

Technical data
Renseignements techniques
Technische Informationen
Informaciones técnicas

212	Modular System
-----	----------------

214 Pezzi speciali

Special trims
Pieces spéciales
Sonderstücke
Piezas especiales

216	Schemi di posa
-----	----------------

Laying patterns
Schémas de pose
Verlegungsschemen
Esquemas de colocación

CARATTERISTICHE TECNICHE

Technical Specifications
Caracteristiques Techniques
Technische Daten
Características Técnicas

220	Stone
221	Le Porcellane Smaltate
222	Progetto
223	Habitat



Pastorelli, fondata nel 1967, vanta oggi un'esperienza di oltre 40 anni nella realizzazione di pavimenti e rivestimenti in ceramica. Attiva produttivamente nei due stabilimenti di Savignano sul Panaro, l'azienda è stata una delle prime a produrre gres porcellanato divenendo negli anni 90 un riferimento nel settore per creatività ed innovazione di prodotto.

La perizia delle risorse umane, maturata durante questo lungo periodo, combinata con le potenzialità della più moderna tecnologia recentemente introdotta, hanno permesso il raggiungimento di elevatissimi standard qualitativi ed estetici.

L'appartenenza ad un gruppo industriale di rilievo, ha consentito infine al marchio Pastorelli di affrontare con fiducia il mercato mondiale. La sfida continua ancora oggi con obiettivi ambiziosi come quello che l'ha portata ad associarsi al Green Building Council Italia e a lanciare la serie "Opera", ideata per ottenere la certificazione LEED degli edifici.



Pastorelli, founded in 1967, today boasts an experience of over 40 years in the construction of floor and wall tiles. Productively active in the two factories of Savignano sul Panaro, Pastorelli was one of the first companies to produce gres porcelain in the 90s, becoming a reference in the field for creativity and product innovation.

The expertise of human resources, gained during this long period, combined with the potential of modern technology, recently introduced, have enabled the achievement of high standards of quality and aesthetic.

Belonging to a major industrial group, has finally allowed the trademark Pastorelli confidence to deal with the global market.

The challenge continues today with ambitious goals such as leading the company to join the Green Building Council Italy and to launch the series "Opera", designed to achieve the LEED certification of buildings.

Pastorelli, société crée en 1967, peut se vanter d'une expérience de plus de 40 ans dans la réalisation de sols et revêtements en carrelage. La production de Pastorelli deroule son activité dans les deux établissements de Savignano sul Panaro, elle a été une des premières sociétés a produire du grés cérame en devenant dans les années 90 une référence du secteur pour sa créativité et innovation des produits.

L'expertise dans les ressources humaines, qui à muri pendant cette longue période en combinaison avec le potentiel des technologies des plus modernes, ont permis d'obtenir de très hauts standard de qualités et d' esthétismes.

L'appartenance à un groupe industriel important, a permis d'affronter avec optimisme le marché mondial. Le défi continu encore aujourd'hui avec des objectifs ambitieux comme celui de s'associer au Green Building Council Italia et de lancer la serie Opera crée pour obtenir la certification Leed des bâtiments.

Pastorelli – im Jahre 1967 gegründet – kann heute auf eine über 40jährige Erfahrung bei der Herstellung von Wand- und Bodenfliesen zurückblicken. Mit zwei Produktionswerken in Savignano sul Panaro zählt die Pastorelli zu den führenden Herstellern von Feinsteinzeug (Gres Procellanto).

Resultat langjähriger Erfahrung und kürzlich eingeführter modernster, zukunftsweisender Produktionstechnik, ist die hohe Qualität und Ästhetik unserer Produkte.

Die Partnerschaft mit einem wichtigen Industrieunternehmen erlaubt der Pastorelli, mit großen Vertrauen und Zuversicht den Weltmarkt zu erobern. Diese Herausforderung geht mit ehrgeizigen Zielen, wie zum Beispiel dem Anschluss an die Green Building Council Italia und der Einführung der Serie „Opera“, die mit dem Zertifikat LEED ausgezeichnet wurde, einher.

Pastorelli, empresa nacida en el año 1967 puede jactarse de una experiencia de mas de 40 años en la realizacion de suelos y revestimientos en ceramica. La produccion se desarrolla en las dos plantas de Savignano sul Panaro. La empresa ha sido una entre las primeras a producir Gres Porcelanico, haciendose en los años '90 un referente del sector para la creatividad y la innovaciòn des productos.

La pericia de los recursos humanos, madurada durante este lungo periodo, junto a la potencialidad de la mas moderna tecnologia, han permitido l'acabamiento de standard de qualidad y estéticos.

La pertenencia a un grupo Industrial de relieve, ha permitido de enfrentarse con el mercado mundial con confianza. El desafio sigue todavia ahoy con objetivos ambiciosos, como lo que ha portado a reunirse al Green Building Council Italia y crear la serie Opera, creada para obtener la certification LEED de los edificios.

GRES PORCELLANATO A TUTTO SPESSORE

FULL DEPTH VITRIFIED STONEWARE - GRÈS CERAME À TOUTE EPAISSEUR - FEINSTEINZEUG AUF GANZER DICKE - GRES PORCELÁNICO A TODO ESPESOR

**Residenziale, bagni, cucine, interni, esterni, scale, davanzali.
Showrooms commerciali, alberghi, aeroporti, negozi, uffici, ristoranti.**



Housing, bathrooms,
kitchens, interiors,
exteriors, stairs,
window ledges.

Zones résidentielles,
salles de bains,
cuisines, escaliers,
rebords.

Wohnräume, Bäder,
Küchen,
Innen- und Außenräume,
Treppen, Simse.

Chalets, cuartos de baño,
cocinas, interiores,
exteriores, escaleras,
alféizares.

Sales showrooms, hotels,
airports, shops,
offices, restaurants.

Showrooms commerciaux, hôtels,
aéroports, magasins,
bureaux, restaurants.

Verkauf-Schauräume, Hotels,
Flughäfen, Geschäfte,
Büros, Restaurants.

Salas de exposición comerciales,
hoteles, aeropuertos, tiendas,
oficinas, restaurantes.

RESISTENZA all'ABRASIONE

*Abrasion Resistance
Résistance À L'abrasion
Abriebfestkeit
Resistencia A La Abrasión*

RESISTENZA al GELO

*Frost Resistance
Résistance Au Gel
Frostbeständigkeit
Resistencia Al Hielol*

RESISTENZA ai CARICHI di ROTTURA

*Breaking Load Resistance
Résistance Aux Charges De Rupture
Bruchlastbeständigkeit
Resistencia A Las Cargas De Ruptura*

RESISTENZA agli ACIDI

*Acid Resistance
Résistance Aux Acides
Säurefestkeit
Resistencia A Los Ácidos*

RESISTENZA agli URTI

*Impact Strength
Résistance Aux Chocs
Schlagfestkeit
Resistencia A Los Golpes*

RESISTENZA alle MACCHIE

*Stain Resistance
Résistance Aux Taches
Fleckenbeständigkeit
Resistencia A Las Manchas*

pastorelli



AYERS ROCK

20x20 8"x8". 20x40 8"x16".

SHADE SPECTRUM

Low Moderate High Random

DIN 51130	DIN 51097	ASTM C1028	B.C.R.A.
R12	C	dry ≥ 0,60 wet ≥ 0,60	dry ≥ 0,40 wet ≥ 0,40

FORMATO	SPESSORE	Pzx	Mqx	Kgx	Mqx	Kgx
20x20	10,3	25	1	20,8	45	956,00
20x40	10,3	13	1,04	21,5	46,8	987,50

ROCK BROWN



20x20 20x40

75 75 75 75



Ventaglio Brown-Grey 1 m² = 3 pz. (201)

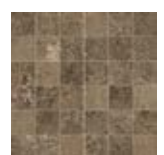

Mosaico 30x30 (5x5) (230)

ROCK GREY



20x20 20x40

75 75 75 75



Ventaglio Grey-White 1 m² = 3 pz. (201)



Mosaico 30x30 (5x5) (230)

ROCK WHITE



20x20 20x40

75 75 75 75

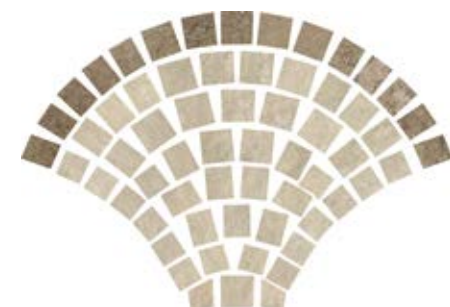

Ventaglio White-Brown 1 m² = 3 pz. (201)



Mosaico 30x30 (5x5) (230)

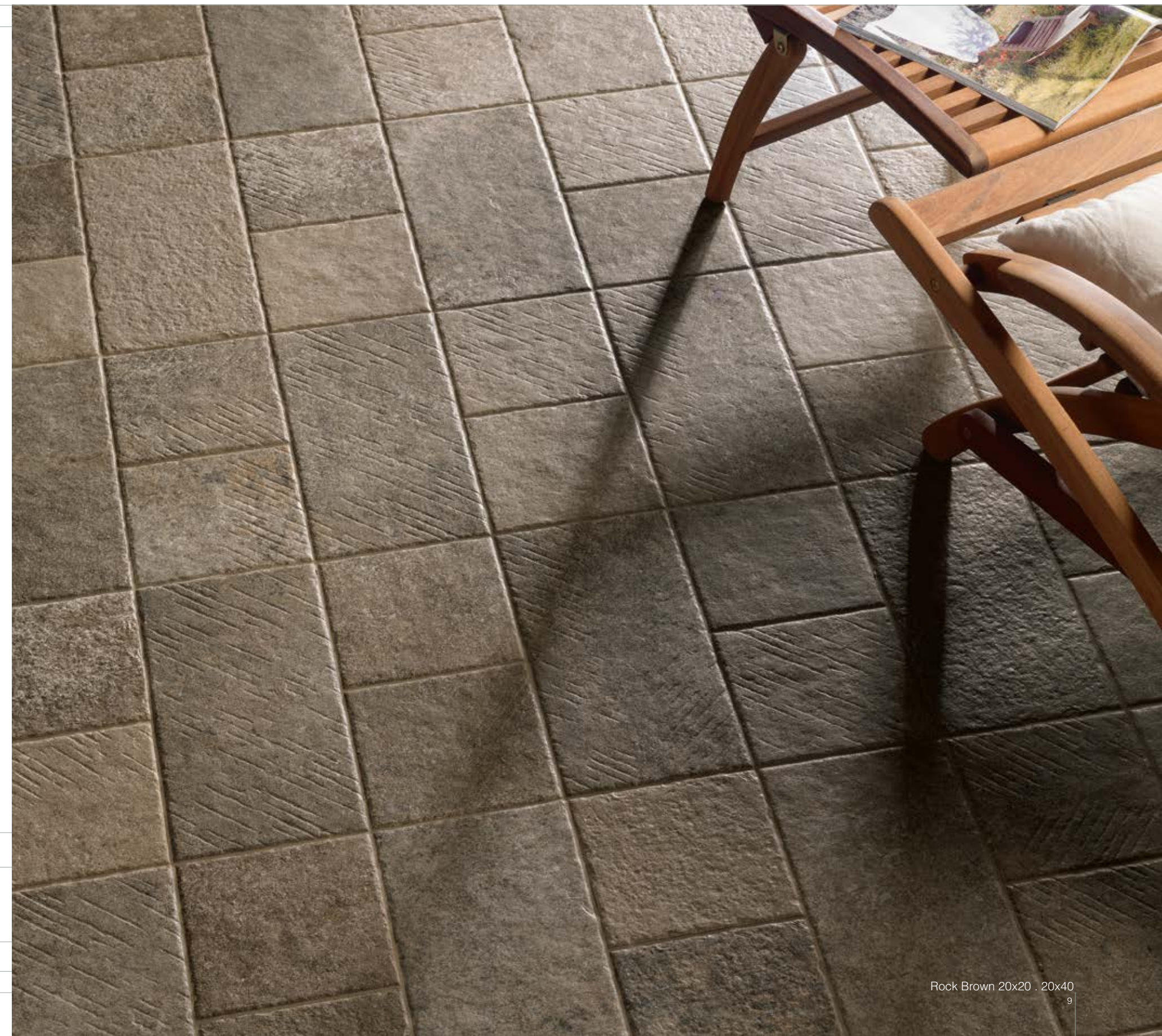

Pezzi SPECIALI

Special trims - Sonderstücke - Piezas especiales - Piezas especiales

Battiscopa 10x40 (11)

Elemento a "L" monolitico "pressato" 4x15x30 (R12) (121)

DISPONIBILE IN TUTTI I COLORI
Available in all colours - In allen Farben erhältlich - Disponible dans toutes les couleurs - Se comercializa en todos los colores



AYERS ROCK

20x20⁸x8". 20x40⁸x16".

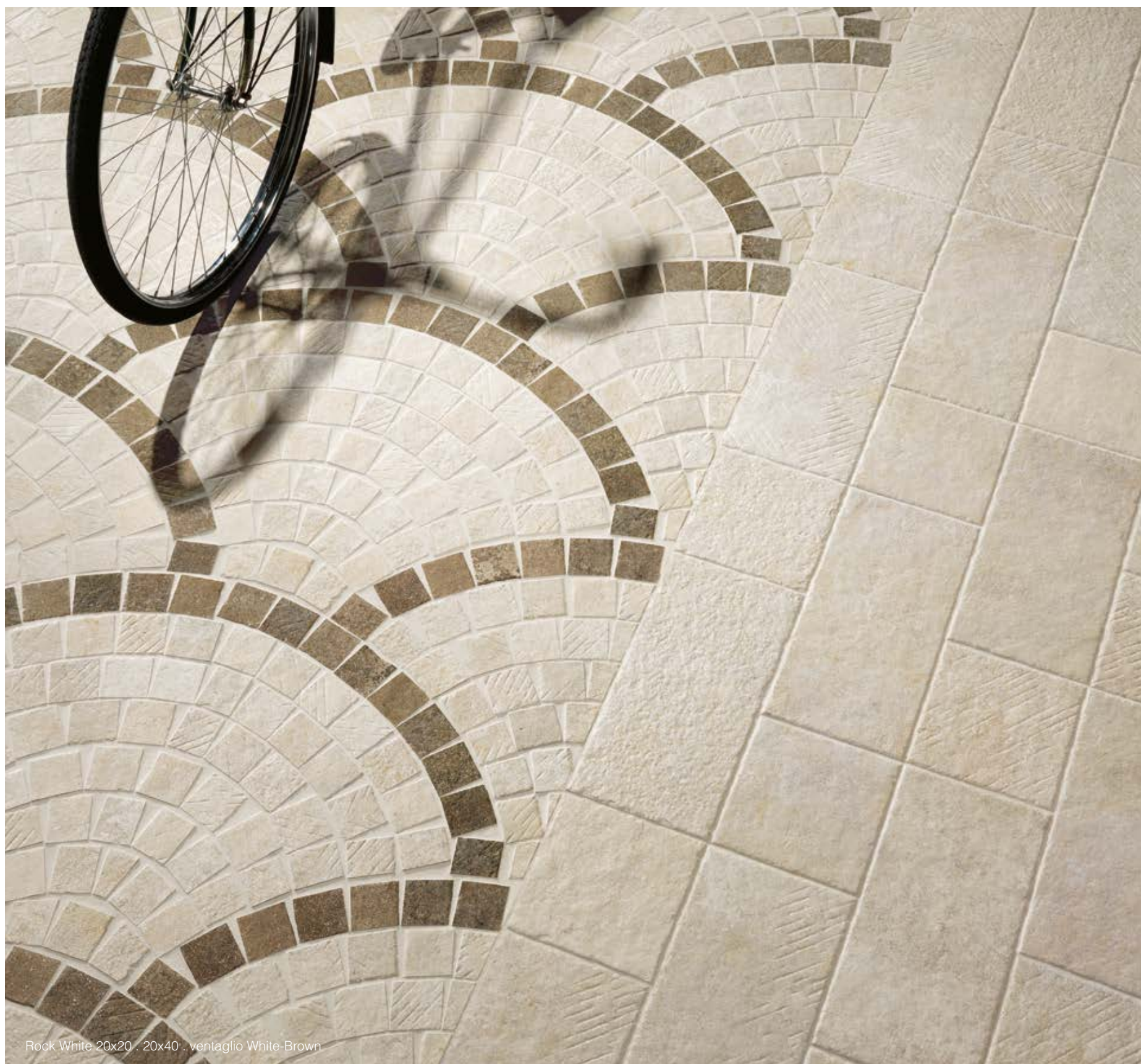

Rock White 20x20 . 20x40 . ventaglio White-Brown



Rock Grey 20x20 . 20x40 . elemento a L monolitico



ATELIER

60x120^{24"x48"} 60x120 20 mm ^{24"x48"} .30x120^{12"x48"} .30x120 20 mm ^{12"x48"} 20x120^{8"x48"}

SHADE SPECTRUM			
Low <input type="checkbox"/>	Moderate <input type="checkbox"/>	High <input type="checkbox"/>	Random <input type="checkbox"/>

DIN 51130	DIN 51097	D.C.O.F.	B.C.R.A.
		wet ≥ 0,42	dry ≥ 0,40 wet ≥ 0,40

20MM			
DIN 51130	DIN 51097	D.C.O.F.	B.C.R.A.
		≥ 0,42	dry ≥ 0,40 wet ≥ 0,40

FORMATO	SPESSORE	Pz x	Mqx	Kgx	x	Mqx	Kgx
30x120	10,3	3	1,08	27,00	30	32,40	810,00
20x120	10,3	4	0,96	23,12	36	34,56	832,32
60x120	20	1	0,72	33,80	26	18,72	880,00
30x120	20	2	0,72	32,50	16	11,52	520,00

AT CORDA



60x120 nat. **20mm**
60x120 rett. **20mm** (€ 114,80)



30x120 rett. **20mm**



30x120 rett.



20x120 rett.

AT BIANCO



30x120 rett.



20x120 rett.



mosaico MIX 30x30



muretto 10x60



mosaico MIX 30x30



muretto 10x60

Pezzi SPECIALI

Special trims - Pieces especiales - Sonderstücke - Piezas especiales

20MM

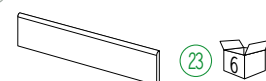

● Battiscopa 6,5x120 rett.

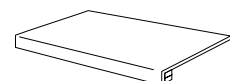

● Gradone Assemblato. 3x20x120 rett.



- Gradone Lineare 2x60x120 nat.
- Gradone Lineare 2x60x120 rett.

● DISPONIBILE IN TUTTI I COLORI
Available in all colours - Disponible dans toutes les couleurs - In allen Farben erhältlich - Se comercializas en todos los colores



ATELIER

60x120^{24"x48"} 60x120 20 mm ^{24"x48"} .30x120^{12"x48"} .30x120 20 mm ^{12"x48"} 20x120^{8"x48"}

SHADE SPECTRUM			
Low <input type="checkbox"/>	Moderate <input checked="" type="checkbox"/>	High <input type="checkbox"/>	Random <input type="checkbox"/>

DIN 51130	DIN 51097	D.C.O.F.	B.C.R.A.
		wet ≥ 0,42	dry ≥ 0,40 wet ≥ 0,40

20MM	DIN 51130	DIN 51097	B.C.R.A.	D.C.O.F.
		dry ≥ 0,40 wet ≥ 0,40	≥ 0,42	

FORMATO	SPESSORE	Pzx	Mqx	Kgx		Mqx	Kgx
30x120	10,3	3	1,08	27,00	30	32,40	810,00
20x120	10,3	4	0,96	23,12	36	34,56	832,32
60x120	20	1	0,72	33,80	26	18,72	880,00
30x120	20	2	0,72	32,50	16	11,52	520,00

AT ANTRACITE

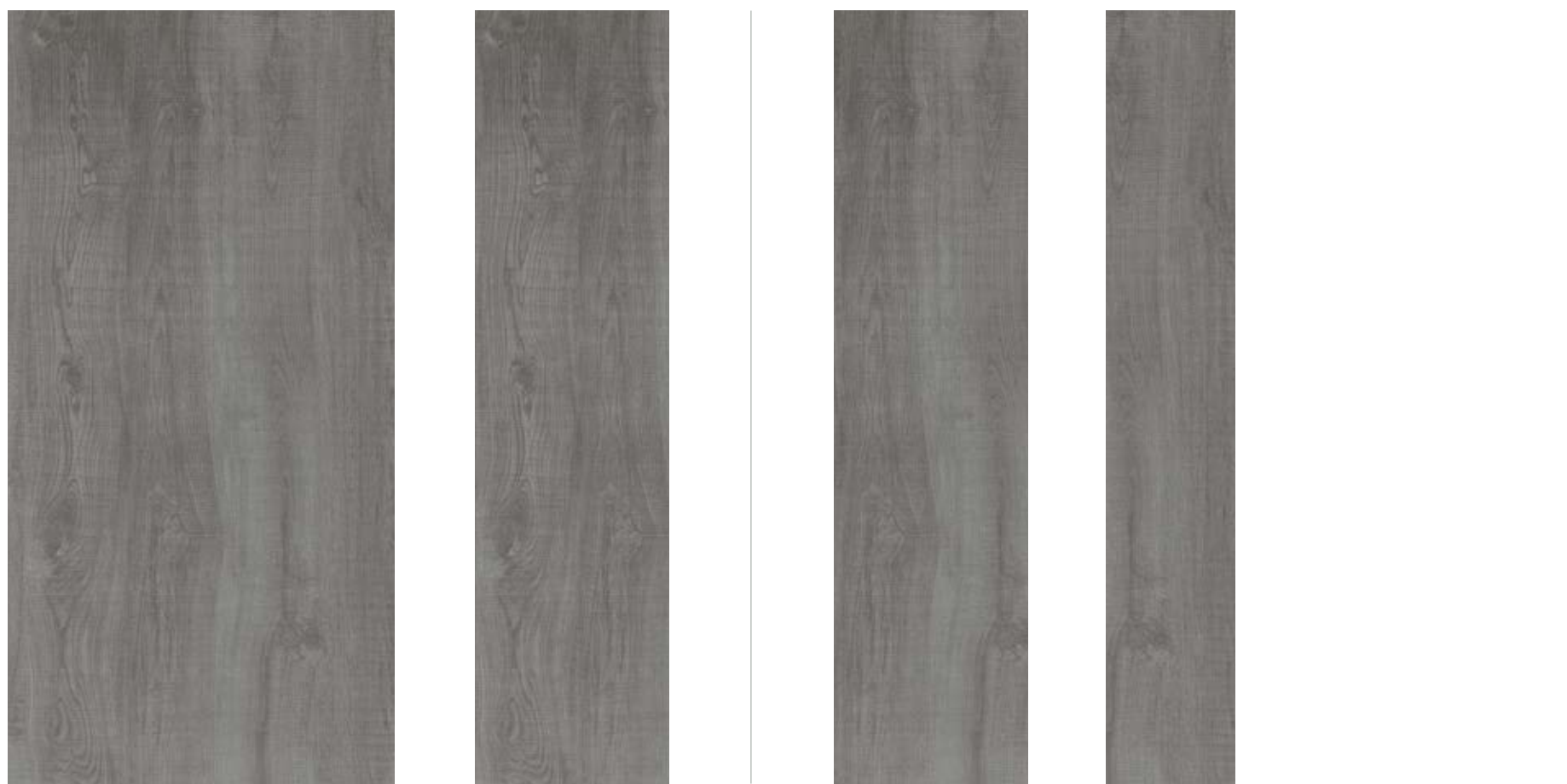

60x120 nat. **20mm**
 60x120 rett. **20mm** (€ 114,80)

30x120 rett. **20mm**
 30x120 rett.
 20x120 rett.

AT BRUNO



60x120 nat. **20mm**
 60x120 rett. **20mm** (€ 114,80)

30x120 rett. **20mm**
 30x120 rett.
 20x120 rett.



mosaico MIX 30x30



muretto 10x60



mosaico MIX 30x30



muretto 10x60

Pezzi SPECIALI

Special trims - Piezas especiales - Sonderstücke - Piezas especiales

● Battiscopa 6,5x120 rett.	● Gradone Assemblato. 3x20x120 rett.	● Gradone Lineare 2x60x120 nat.	● Gradone Lineare 2x60x120 rett.

● DISPONIBILE IN TUTTI I COLORI
Available in all colours - Disponible dans toutes les couleurs - In allen Farben erhältlich - Se comercializas en todos los colores



ATELIER

60x120^{24"x48"} .60x120 20 mm ^{24"x48"} .30x120^{12"x48"} .30x120 20 mm ^{12"x48"} 20x120^{8"x48"} .

IN. atelier antracite 30x120 . 20x120
OUt. atelier antracite 60x120 20mm . 30x120 20mm



Atelier bianco 20x120



ATELIER

60x120^{24"x48"} . 60x120 20 mm ^{24"x48"} . 30x120^{12"x48"} . 30x120 20 mm ^{12"x48"} 20x120^{8"x48"} .

Atelier muretto Bruno 10x80 . Bruno 20x120 . 30x120



IN. Atelier corda 30x120 . mosaico mix 30x30
OUT. Atelier corda 30x120 20mm . 60x120 20mm



DUOMO

30x60^{12"x24"} . 30x30^{12"x12"} . 15x15^{6"x6"}

SHADE SPECTRUM

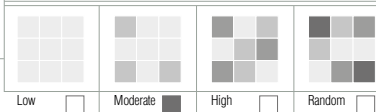

DIN 51130

DIN 51097

ASTM C1028

B.C.R.A.

R10

B

dry ≥ 0,60

dry ≥ 0,40

wet ≥ 0,60

wet ≥ 0,40

FORMATO	SPESSORE	Pz x	Mqx	Kgx	Mqx	Kgx
30x60	10	6	1,08	23,5	40	940
30x30	8,5	15	1,35	25,00	40	1000
15x15	9,0	52	1,20	22,00	60	1320

ROMANICO

GOTICO

BAROCCO

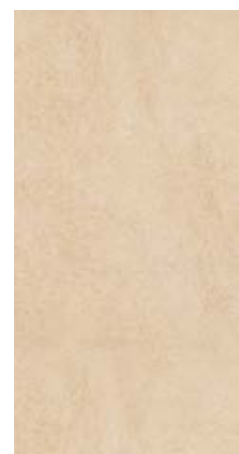

30x60

85 85



30x60

85 85



30x60

85 85

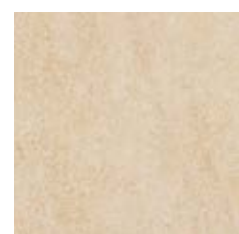

30x30

31 31

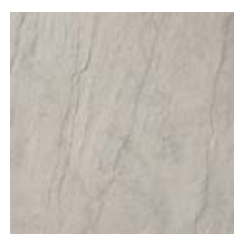

30x30

31 31

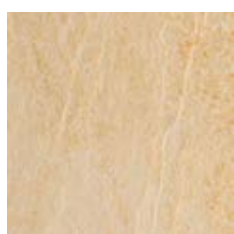

30x30

31 31



15x15

37 37

6x6

1 24



15x15

37 37

6x6

1 24



15x15

37 37

6x6

1 24



Fascia Epoca Romanico 6x30

89

12



Ang. Epoca Romanico 6x6

35



Fascia Epoca Gotico 6x30

89

12



Ang. Epoca Gotico 6x6

35



Fascia Epoca Barocco 6x30

89

12



Ang. Epoca Barocco 6x6

35



Rosone Gotico. 60x60

277



Rosone Multicolor. 60x60

277



Pezzi SPECIALI

Special trims - Piezas especiales - Sonderstücke - Piezas especiales

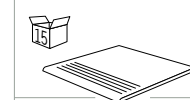

Gradino NAT. 30x30 43

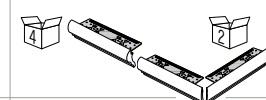

Profilo Gradino. 4x4,5x30 143

Angolo Profilo Gradino. 4x4,5x33 203

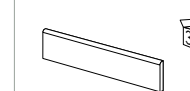

Battiscopa NAT. 8x30 11

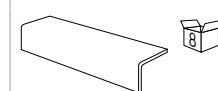

Elemento a "L" monolitico "pressato" 4x15x30 123



HIMALAYA

45x45^{18"x18"}.30x60^{12"x24"}.30x30^{12"x12"}

SHADE SPECTRUM

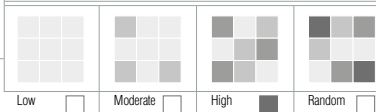

DIN 51130

DIN 51097

ASTM C1028

R10

A

dry ≥ 0,60

wet ≥ 0,60

FORMATO	SPESSORE	Pz x	Mqx	Kgx	Mqx	Kgx
45x45	9,5	5	1,01	24,00	34	34,34
30x60	10	6	1,08	23,50	40	43,20
30x30	8,5	16	1,35	25,00	40	54,00

EVEREST

K2

PUMORI

MAKALÙ



45x45

64 64



45x45

64 64



45x45

64 64



45x45

93 93

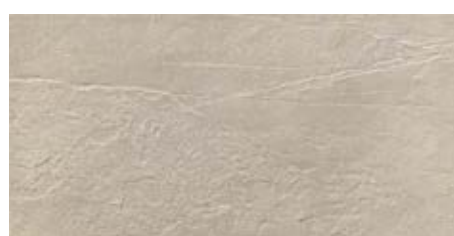

30x60

85 85



30x30

46 46

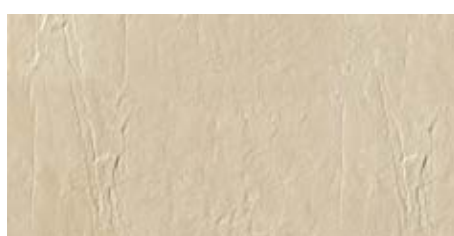

30x60

85 85

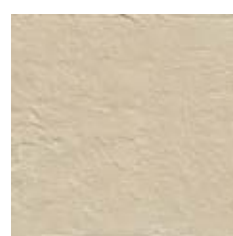

30x30

46 46



30x60

85 85



30x30

46 46



30x60

107 107



30x30

79 79



Mosaico 30x30 (5x5) 230 230 5



Mosaico 30x30 (5x5) 230 230 5

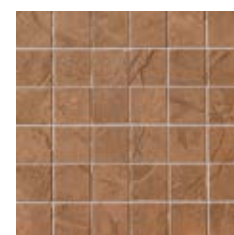

Mosaico 30x30 (5x5) 230 230 5



Mosaico 30x30 (5x5) 230 230 5



Listello 4,5x60

119 4



Angolo 4,5x4,5 67 6



Listello 4,5x60

119 4



Angolo 4,5x4,5 67 6



Listello 4,5x60

119 4



Angolo 4,5x4,5 67 6



Listello 4,5x60

119 4



Angolo 4,5x4,5 67 6



Listello Alluminio 0,6x60

139 10



Ang. alluminio 0,6x0,6 19 1



Listello Alluminio 0,6x60

139 10



Ang. alluminio 0,6x0,6 19 1



Listello Alluminio 0,6x60

139 10



Ang. alluminio 0,6x0,6 19 1



Listello Alluminio 0,6x60

139 10



Ang. alluminio 0,6x0,6 19 1

Pezzi SPECIALI

Special trims - Piezas especiales - Sonderstücke - Piezas especiales

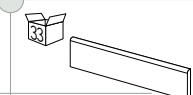

Battiscopa. 7,2x30 11

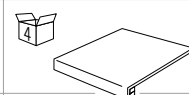

Gradone Assemblato. 3x33x30 191

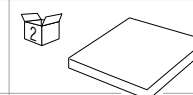

Gradone Ang. Assemblato. 3x33x33 223

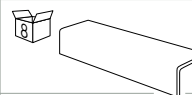

Elemento a "L" monolitico 4,5x16,5x30 123



HIMALAYA

45x45 18"x18" . 30x60 12"x24" . 30x30 12"x12"

SHADE SPECTRUM

Low Moderate High Random

DIN 51130 **R10** DIN 51097 **A** ASTM C1028

dry ≥ 0,60
wet ≥ 0,60

FORMATO	SPESSORE	Pz x	Mqx	Kgx	Mqx	Kgx
45x45	9,5	5	1,01	24,00	34	34,34
30x60	10	6	1,08	23,50	40	43,20
30x30	8,5	16	1,35	25,00	40	54,00

ANNAPURNA



45x45 (93) (93)



30x60 (107) (107)



30x30 (79) (79)

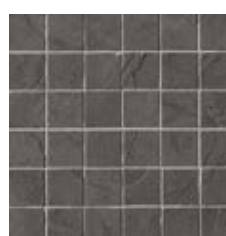

Mosaico 30x30 (5x5) (230) (230)



Listello 4,5x60 (119) (119)

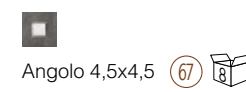

Angolo 4,5x4,5 (67) (67)



Listello Alluminio 0,6x60 (139) (139)

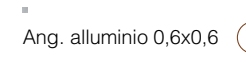

Ang. alluminio 0,6x0,6 (19) (19)

Pezzi SPECIALI

Special trims - Piezas especiales - Sonderstücke - Piezas especiales

- Battiscopa. 7,2x30 (11)
- Gradone Assemblato. 3x33x30 (191)
- Gradone Ang. Assemblato. 3x33x33 (223)
- Elemento a "L" monolitico 4,5x16,5x30 (123)

● DISPONIBILE IN TUTTI I COLORI
Available in all colours - Disponible dans toutes les couleurs - In allen Farben erhältlich - Se comercializas en todos los colores

PAVÉ



Everest Pavé 35x100 (231) (231)



K2 Pavé 35x100 (231) (231)



Pumori Pavé 35x100 (231) (231)



Makalù Pavé 35x100 (231) (231)



Annapurna Pavé 35x100 (231) (231)



Everest 30x60 . 30x30 . listello 4,5x60

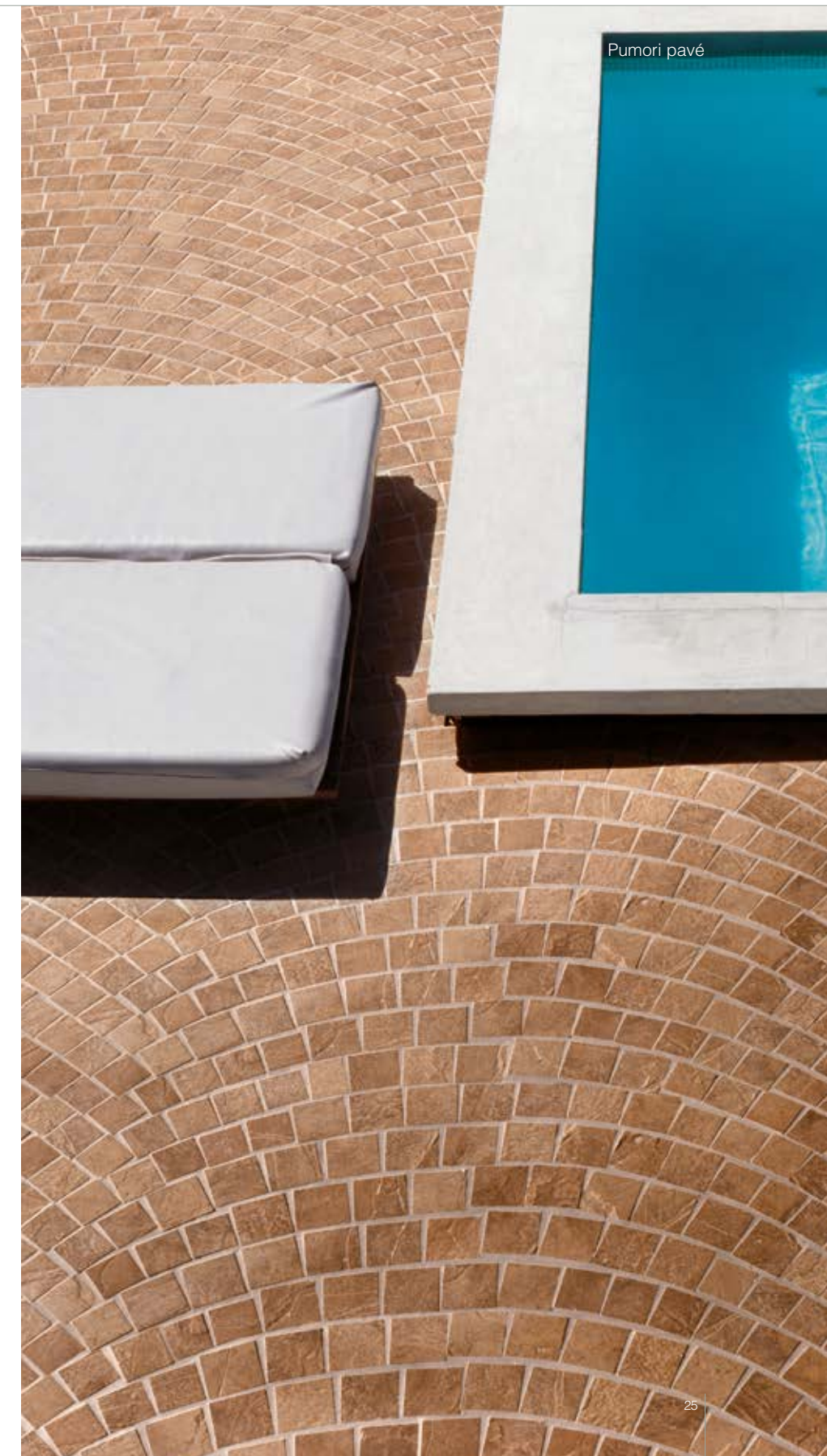

Pumori pavé



LITHOS

60x60^{24"x24"}.30x60^{12"x24"}.45x45^{18"x18"}.

NERO



60x60 nat.

95 95



30x60 nat.

79 79



45x45 nat.

64 64

45x45 lapp. rett.

141 141



Lithos Fascia Nero 5x45

125 6



Mosaico Nero 30x30 (5x5)

5 230 230



Lithos Tozzetto 5x5

51 2



Fascia Metallo 1x30

6 117

SHADE SPECTRUM



Random

NATURALE

DIN 51130

R10

DIN 51097

B

B.C.R.A.

dry ≥ 0,40

wet ≥ 0,40

PERLA



60x60 nat.

95 95

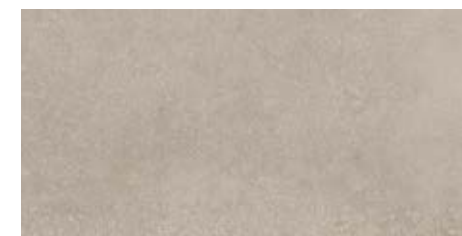

30x60 nat.

79 79



45x45 nat.

64 64

45x45 lapp. rett.

141 141



Lithos Fascia Perla 5x45

125 6



Mosaico Perla 30x30 (5x5)

5 230 230



Lithos Tozzetto 5x5

51 2



Fascia Metallo 1x30

6 117

SHADE SPECTRUM

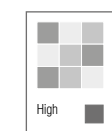

High

Pezzi SPECIALI

Special trims - Pieces especiales - Sonderstücke - Piezas especiales



Battiscopa. 9x45

11



Gradone Assemblato. 3x33x30

191



Gradone Ang. Assemblato. 3x33x33

233

● DISPONIBILE IN TUTTI I COLORI
Available in all colours - Disponible dans toutes les couleurs - In allen Farben erhältlich - Se comercializas en todos los colores



LITHOS

60x60^{24"x24"}.30x60^{12"x24"}.45x45^{18"x18"}.



Nero 60x60
Perla 30x60 . fascia metallo



Nero 45x45 lapp. rett.
TM Grigio decoro 30x60 lapp. rett.



LOFT

60x60^{24"x24"} .30x60^{12"x24"}.

SHADE SPECTRUM

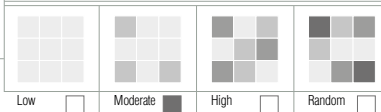

DIN 51130



DIN 51097



ASTM C1028

dry ≥ 0,60
wet ≥ 0,60

B.C.R.A.

dry ≥ 0,40
wet ≥ 0,40

FORMATO	SPESSORE	Pz x	Mqx	Kgx	Mqx	Kgx
60x60	10,3	4	1,44	34,00	43,20	1020
30x60	10,3	6	1,08	23,50	43,20	950

BIANCO



60x60 nat.



30x60 nat.



Mosaico 30x30 (5x5)



Muretto 30x60



GRIGIO



60x60 nat.



30x60 nat.

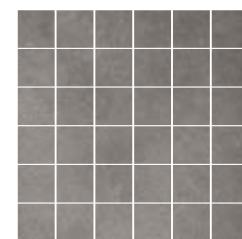

Mosaico 30x30 (5x5)



Muretto 30x60



ANTRACITE

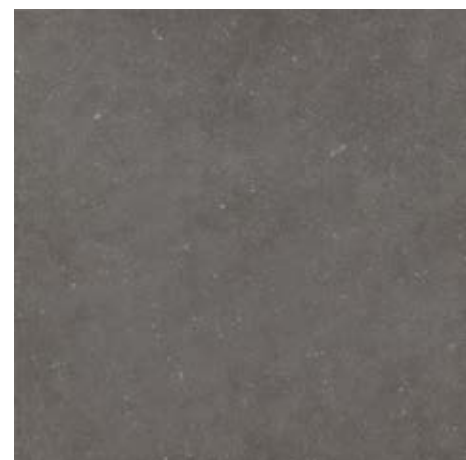

60x60 nat.



30x60 nat.

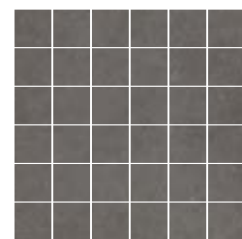

Mosaico 30x30 (5x5)



Muretto 30x60



Pezzi SPECIALI

Special trims - Piezas especiales - Sonderstücke - Piezas especiales

● Battiscopa 7,2x30

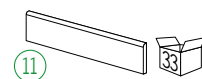

11

Listello Alluminio 0,6x60



139

Fascia Metallo 1x30



117

● DISPONIBILE IN TUTTI I COLORI
Available in all colours - Disponible dans toutes les couleurs - In allen Farben erhältlich - Se comercializas en todos los colores



Bianco 30x60 nat. muretto 30x60

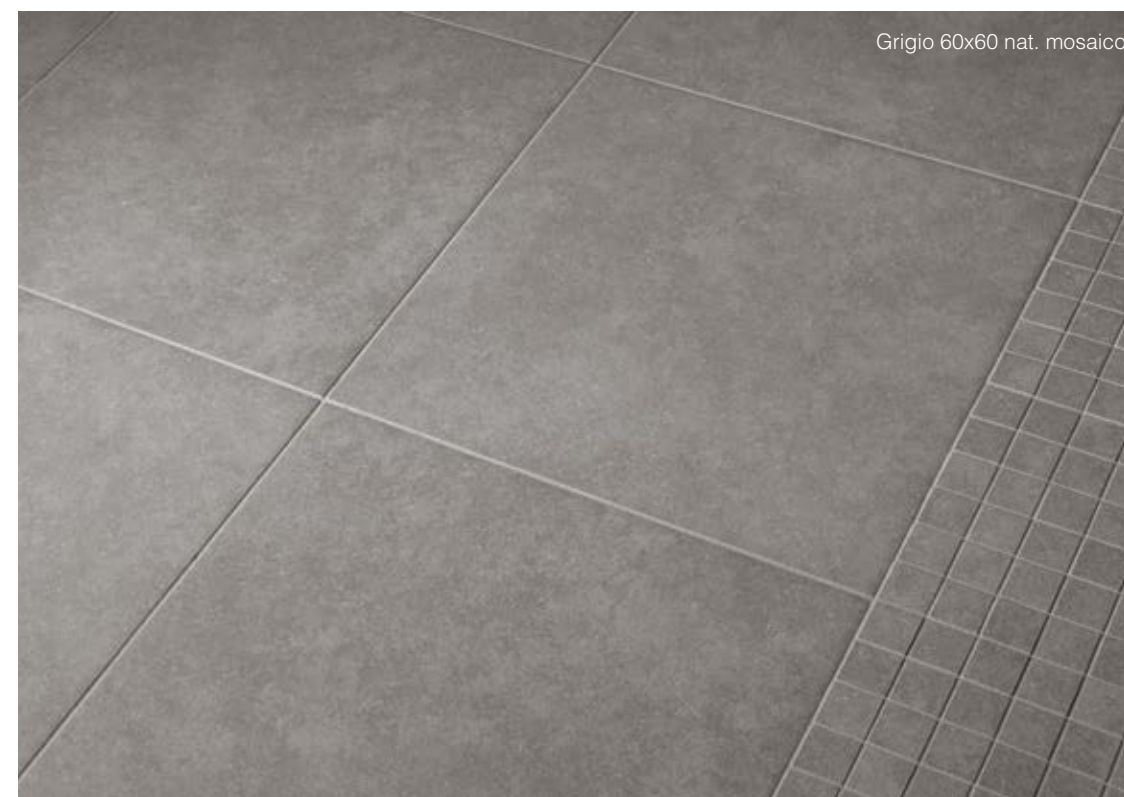

Grigio 60x60 nat. mosaico



Antracite 60x60 nat.
Grigio 30x60 nat. listello alluminio



MANHATTAN

60x60^{24"x24"} .30x60^{12"x24"}.

SHADE SPECTRUM			
Low <input type="checkbox"/>	Moderate <input checked="" type="checkbox"/>	High <input type="checkbox"/>	Random <input type="checkbox"/>

DIN 51130	DIN 51097	ASTM C1028	B.C.R.A.
R9	A	dry ≥ 0,60 wet ≥ 0,60	dry ≥ 0,40 wet ≥ 0,40

FORMATO	SPESSORE	Pz x	Mqx	Kgx	x	Mqx	Kgx
60x60	10	4	1,44	34,00	30	43,20	1020
30x60	10	6	1,08	23,50	40	43,20	950

GRIGIO



NF UPEC
U2S P3 E3 C2

60x60



NF UPEC
U2S P3 E3 C2

30x60



Mosaico Manhattan Grigio
30x30 (5x5)

Fascia Manhattan Grigio 2,2x30

Tozz. Manhattan alluminio 2,2x2,2

BEIGE



NF UPEC
U3 P3 E3 C2

60x60

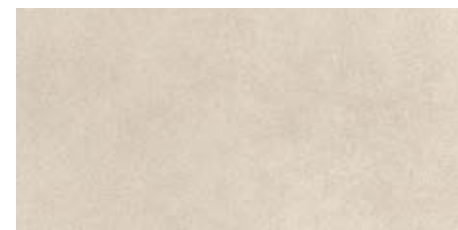

NF UPEC
U3 P3 E3 C2

30x60



Mosaico Manhattan Beige
30x30 (5x5)

Fascia Manhattan Beige 2,2x30

Tozz. Manhattan alluminio 2,2x2,2

MARRONE



60x60



30x60



Mosaico Manhattan Marrone
30x30 (5x5)

Fascia Manhattan Marrone 2,2x30

Tozz. Manhattan alluminio 2,2x2,2

NERO



60x60



30x60

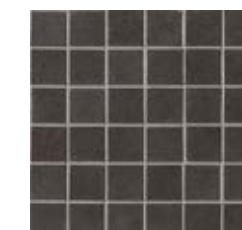

Mosaico Manhattan Nero
30x30 (5x5)

Fascia Manhattan Nero 2,2x30

Tozz. Manhattan alluminio 2,2x2,2

Listello Alluminio
0,6x60

Listello Lux 0,6x60
(solo rivestimento - only wall)

Ang. Alluminio
0,6x0,6

Zip 6x6

Pezzi SPECIALI

Special trims - Piezas especiales - Sonderstücke - Piezas especiales

• Battiscopa. 7,2x30

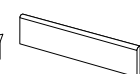

• Profilo Gradino. 4x4,5x30

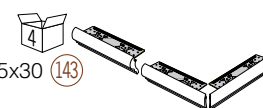

• Angolo Profilo Gradino. 4x4,5x33



• DISPONIBILE IN TUTTI I COLORI

Available in all colours - Disponible dans toutes les couleurs - In allen Farben erhältlich - Se comercializas en todos los colores



MANHATTAN

60x60^{24"x24"} .30x60^{12"x24"} .



Grigio 30x60 . Zip 6x6



Marrone 60x60



Nero 30x60 . listello alluminio



Beige 30x60 . mosaico Manhattanh Marrone



MARFIL

60x60^{24"x24"}.30x60^{12"x24"}.45x45^{18"x18"}.

SHADE SPECTRUM

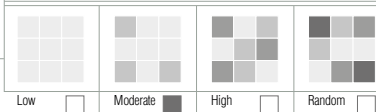

DIN 51097



FORMATO	SPESSORE	Pz x	Mqx	Kgx	Mqx	Kgx
60x60	10	4	1,44	34,00	30	43,20
30x60	9,5	6	1,08	23,50	40	43,20
45x45	9,5	5	1,01	24,00	34	34,34

MARFIL AVORIO



60x60 nat.

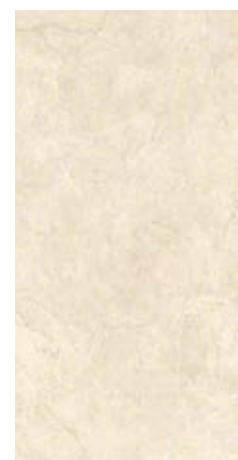

30x60 nat.

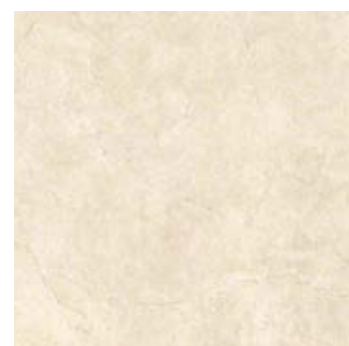

45x45 nat.



Mosaico avorio 30x30 (5x5)



Marfil fascia avorio 2,5x30



Marfil torello avorio 5x30



Marfil ang. torello avorio 5x5



Listello Alluminio 0,6x60



Ang. Alluminio 0,6x0,6



60x60 nat.

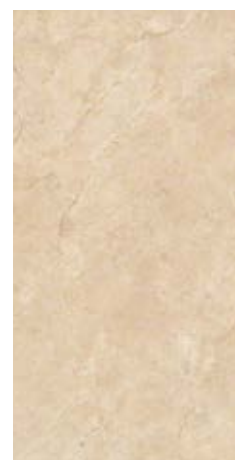

30x60 nat.



45x45 nat.

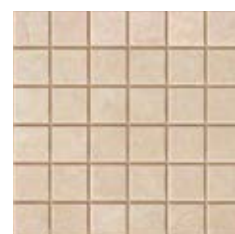

Mosaico beige 30x30 (5x5)



Marfil fascia beige 2,5x30



Marfil torello beige 5x30



Marfil ang. torello beige 5x5



Pezzi SPECIALI

Special trims - Piezas especiales - Sonderstücke - Piezas especiales

Battiscopa NAT. 9x45

12

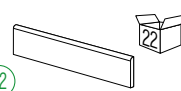

Profilo Gradino. 4x4,5x30

143

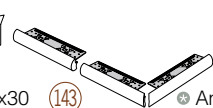

Angolo Profilo Gradino. 4x4,5x33

203



DISPONIBILE IN TUTTI I COLORI

Available in all colours - Disponible dans toutes les couleurs - In allen Farben erhältlich - Se comercializas en todos los colores

Marfil Avorio 60x60
Marfil Avorio 30x60 . mosaico Avorio . Marfil fascia Avorio





MILANO CITY

40x80 16"x31,5". 60x60 24"x24". 60x60 20 mm 24"x24". 30x60 12"x24". 20x80 8"x31,5".

SHADE SPECTRUM

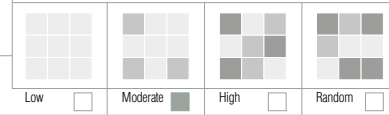

DIN 51130



DIN 51097



ASTM C1028

dry ≥ 0,60
wet ≥ 0,60

B.C.R.A.

dry ≥ 0,40
wet ≥ 0,40

FORMATO	SPESSORE	Pz x	Mqx	Kgx	Mqx	Kgx
60x120	10,3	1	0,72	17,14	42	30,24
30x120	10,3	3	1,08	24,20	20	21,60
40x80	10,3	3	0,96	22,00	28	26,88
20x80	10,3	6	0,96	22,00	28	26,88
60x60	10,3	4	1,44	34,00	30	43,20
30x60	10,3	6	1,08	26,00	40	43,20
60x60	20	2	0,72	33,125	32	23,04
						720,00
						484,00
						618,00
						618,00
						1020,00
						1040,00
						1060,00

CITY GRIGIO



60x120 rett. (173) (173)



30x120 rett. (177) (177)



40x80 nat. (125) (125)

40x80 nat. rett. (161) (161)



60x60 nat. (109) (109)

60x60 nat. rett. (161) (161)

20x80 nat. rett. (171) (171)

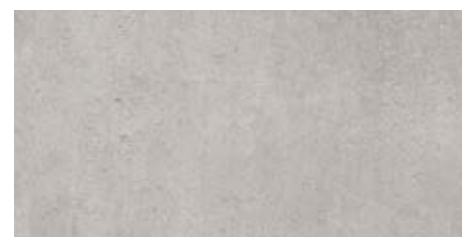

30x60 nat. (87) (87)

30x60 nat. rett. (145) (145)



60x60 nat. 20mm (184) (184) 60x60 rett. 20mm (189) (189)



City Grigio Dec. (179) (179)
30x60 rett.

CITY BEIGE



60x120 rett. (173) (173)

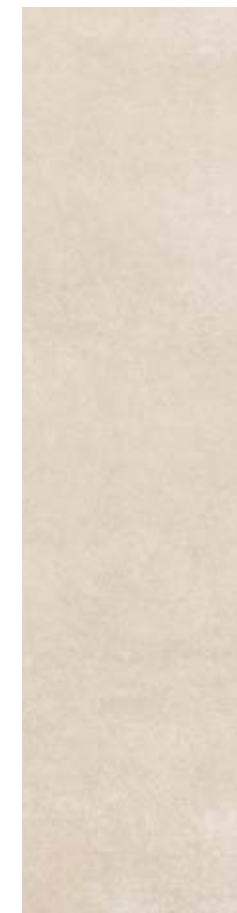

30x120 rett. (177) (177)



40x80 nat. (125) (125)

40x80 nat. rett. (161) (161)

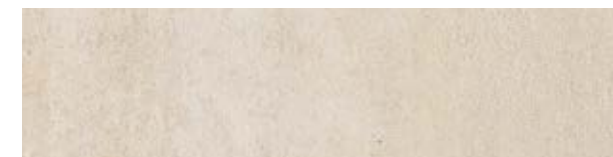

60x60 nat. (109) (109)

60x60 nat. rett. (161) (161)

20x80 nat. rett. (171) (171)

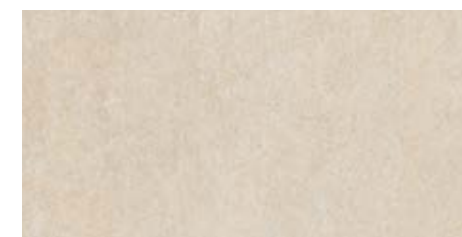

30x60 nat. (87) (87)

30x60 nat. rett. (145) (145)



60x60 nat. 20mm (184) (184) 60x60 rett. 20mm (189) (189)

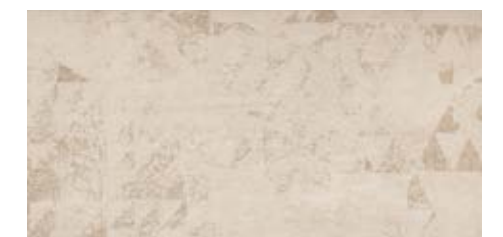

City Beige Dec. (179) (179)
30x60 rett.



Muretto Mix Antracite/Grigio
30x60



Mosaico Mix Bianco/Grigio/Nero
30x26



Mosaico
30x30 (5x5)

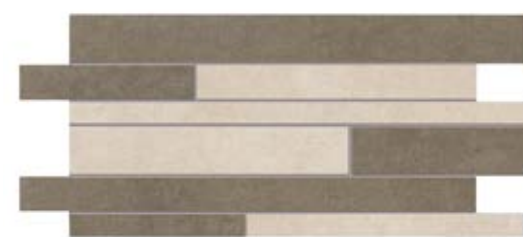

Muretto Mix Beige/Terra
30x60



Mosaico Mix Bianco/Terra/Beige
30x26



Mosaico
30x30 (5x5)



Listello Alluminio 1x80



Listello Alluminio 0,6x60



Pezzi SPECIALI

Special trims - Piezas especiales - Sonderstücke - Piezas especiales

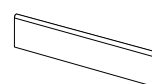

Battiscopa 7,5x60



Gradone Assemblato. 3x33x60

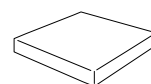

Gradone ang. Assemblato 3x33x33



DISPONIBILE IN TUTTI I COLORI
Available in all colours - Disponible dans toutes les couleurs - In allen Farben erhältlich - Se comercializas en todos los colores



MILANO CITY

40x80 16"x31,5". 60x60 24"x24". 60x60 20 mm 24"x24". 30x60 12"x24". 20x80 8"x31,5".

SHADE SPECTRUM

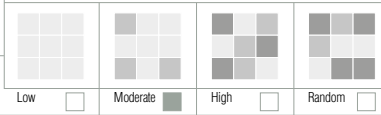

DIN 51130

DIN 51097

ASTM C1028

B.C.R.A.

R9

B

dry ≥ 0,60

dry ≥ 0,40

wet ≥ 0,60

wet ≥ 0,40

FORMATO	SPESSORE	Pz x	Mqx	Kgx	Mqx	Kgx
60x120	10,3	1	0,72	17,14	42	30,24
30x120	10,3	3	1,08	24,20	20	21,60
40x80	10,3	3	0,96	22,00	28	26,88
20x80	10,3	6	0,96	22,00	28	26,88
60x60	10,3	4	1,44	34,00	30	43,20
30x60	10,3	6	1,08	26,00	40	43,20
60x60	20	2	0,72	33,125	32	23,04
						720,00
						484,00
						618,00
						618,00
						1020,00
						1040,00
						1060,00

CITY ANTRACITE



60x120 rett. (173) (173)



30x120 rett. (177) (177)



40x80 nat. (125) (125)

40x80 nat. rett. (161) (161)



20x80 nat. rett. (171) (171)

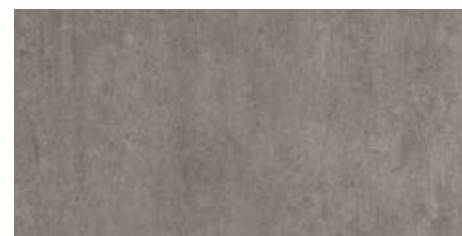

30x60 nat. (87) (87)

30x60 nat. rett. (145) (145)



60x60 nat. (109) (109)

60x60 nat. rett. (161) (161)

60x60 nat. 20mm (184) (184) 60x60 rett. 20mm (189) (189)

CITY TERRA



60x120 rett. (173) (173)



30x120 rett. (177) (177)



40x80 nat. (125) (125)

40x80 nat. rett. (161) (161)



20x80 nat. rett. (171) (171)



30x60 nat. (87) (87)

30x60 nat. rett. (145) (145)



60x60 nat. (109) (109)

60x60 nat. rett. (161) (161)



Muretto Mix Antracite/Grigio 30x60



Listello Alluminio 1x80



Mosaico Mix Bianco/Grigio/Nero 30x26



Listello Alluminio 0,6x60



Mosaico 30x30 (5x5)



Muretto Mix Beige/Terra 30x60



Listello Alluminio 1x80



Mosaico Mix Bianco/Terra/Beige 30x26



Listello Alluminio 0,6x60



Mosaico 30x30 (5x5)



Pezzi SPECIALI

Special trims - Piezas especiales - Sonderstücke - Piezas especiales

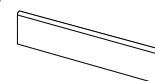

Battiscopa 7,5x60

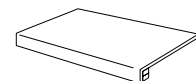

Gradone Assemblato. 3x33x60

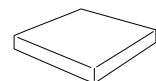

Gradone ang. Assemblato 3x33x33



DISPONIBILE IN TUTTI I COLORI
Available in all colours - Disponible dans toutes les couleurs - In allen Farben erhältlich - Se comercializas en todos los colores



MILANO CITY

40x80^{16"x31,5"}.60x60^{24"x24"}.60x60 20 mm^{24"x24"}.30x60^{12"x24"}.20x80^{8"x31,5"}.



Terra 40x80 Nat. - Mosaico Mix Bianco/Terra/Beige 30x26



Beige 40x80 Nat. - Beige 20x80 Nat.



MILANO CITY

40x80_{16"x31,5"}.60x60_{24"x24"}.60x60 20 mm_{24"x24"}.30x60_{12"x24"}.20x80_{8"x31,5"}.



Antracite 60x60 Nat.



Grigio 30x60



MILANO CITY

40x80^{16"x31,5"}.60x60^{24"x24"}.60x60 20 mm^{24"x24"}.30x60^{12"x24"}.20x80^{8"x31,5"}.

Grigio Dec 30x60 - Grigio 30x60



Grigio 20x80 - Listello alluminio 1x80 - Muretto Mix Antracite/Grigio 30x60
Grigio 40x80 Nat. - Mosaico Grigio 30x30





PIERRE ROYALE

40x80^{16"x31,5"}. 30x60^{12"x24"}. 45x45^{18"x18"}. 20x80^{8"x31,5"}. 12x30^{4 3/4"x12"}.

SHADE SPECTRUM			
Low <input type="checkbox"/>	Moderate <input type="checkbox"/>	High <input type="checkbox"/>	Random <input type="checkbox"/>

GRIP	NATURALE	NATURALE	NATURALE	NATURALE		FORMATO	SPESSORE	Pz	Mqx	Kgx		Mqx	Kgx
DIN 51130	DIN 51130	DIN 51097	ASTM C1028	B.C.R.A.	D.C.O.F.	40x80	10,3	3	0,96	22,00	28	26,88	618
			dry ≥ 0,60	dry ≥ 0,40	≥ 0,42	20x80	10,3	6	0,96	22,00	28	26,88	618
			wet ≥ 0,60	wet ≥ 0,40		45x45	10,3	5	1,01	21,00	34	34,34	816
						30x60	10,3	6	1,08	23,50	40	43,20	950
						12x30	10,3	24	0,86	20,00	60	51,16	1200

PR BLANC

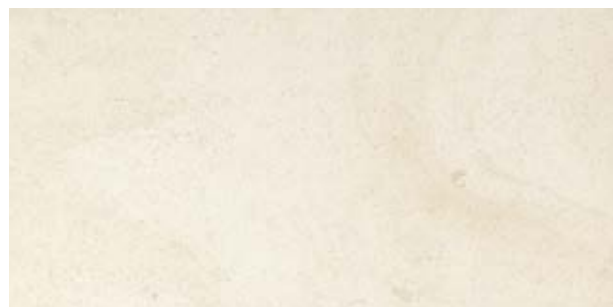

40x80 nat.
40x80 nat. rett.



20x80 nat. rett.



45x45 nat. 12x30 grip



30x60 nat.
30x60 grip



Mosaico Blanc Grip 30x30 (5x5)



Mosaico Blanc Nat. 30x30 (5x5)



Muretto Blanc Grip 30x60

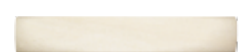

Torello Blanc 6x30



Ang. torello Blanc 6x3



Fascia Royale Blanc 2,5x30



Fascia Metallo 1x30



Listello Alluminio 1x80

PR BEIGE



40x80 nat.
40x80 nat. rett.



20x80 nat. rett.



45x45 nat. 12x30 grip

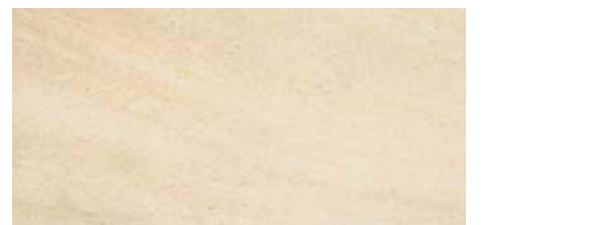

30x60 nat.
30x60 grip



Mosaico Beige Grip 30x30 (5x5)

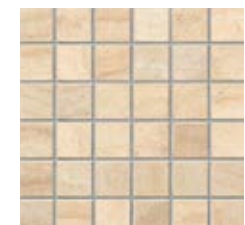

Mosaico Beige Nat. 30x30 (5x5)



Muretto Beige Grip 30x60



Torello Beige 6x30



Ang. torello Beige 6x3



Fascia Royale Beige 2,5x30



Fascia Metallo 1x30



Listello Alluminio 1x80

Pezzi SPECIALI

Special trims - Piezas especiales - Sonderstücke - Piezas especiales

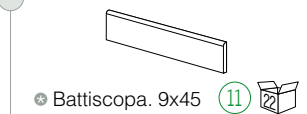

Battiscopa. 9x45

- Gradone Assemblato grip. 3x33x30
- Gradone Assemblato nat. 3x33x30

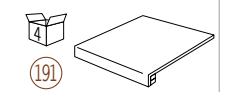

- Gradone Ang. Assemblato grip sx. 3x33x30
- Gradone Ang. Assemblato grip dx. 3x33x30
- Gradone Ang. Assemblato nat sx. 3x33x30
- Gradone Ang. Assemblato nat dx. 3x33x30

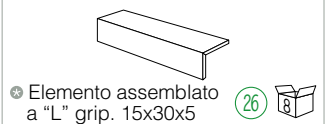
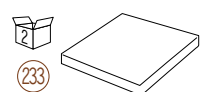

Elemento assemblato a "L" grip. 15x30x5

DISPONIBILE IN TUTTI I COLORI
Available in all colours - Disponible dans toutes les couleurs - In allen Farben erhältlich - Se comercializas en todos los colores



PIERRE ROYALE

40x80^{16"x31,5"}. 30x60^{12"x24"}. 45x45^{18"x18"}. 20x80^{8"x31,5"}. 12x30^{4 3/4"x12"}.

SHADE SPECTRUM			
Low <input type="checkbox"/>	Moderate <input type="checkbox"/>	High <input type="checkbox"/>	Random <input type="checkbox"/>

GRIP	NATURALE	NATURALE	NATURALE	NATURALE	
DIN 51130	DIN 51130	DIN 51097	ASTM C1028	B.C.R.A.	D.C.O.F.
			dry ≥ 0,60 wet ≥ 0,60	dry ≥ 0,40 wet ≥ 0,40	≥ 0,42

FORMATO	SPESSORE	Pzx	Mqx	Kgx		Mqx	Kgx
40x80	10,3	3	0,96	22,00	28	26,88	618
20x80	10,3	6	0,96	22,00	28	26,88	618
45x45	10,3	5	1,01	21,00	34	34,34	816
30x60	10,3	6	1,08	23,50	40	43,20	950
12x30	10,3	24	0,86	20,00	60	51,16	1200

PR GRIS



40x80 nat.

40x80 nat. rett.



20x80 nat. rett.



45x45 nat.



12x30 grip



30x60 nat.

30x60 grip



Mosaico Gris Grip 30x30 (5x5)



Mosaico Gris Nat. 30x30 (5x5)



Muretto Gris Grip 30x60



Torello Gris 6x30



Ang. torello Gris 6x3



Fascia Royale Gris 2,5x30



Fascia Metallo 1x30



Listello Alluminio 1x80

Pezzi SPECIALI

Special trims - Piezas especiales - Sonderstücke - Piezas especiales



Battiscopa. 9x45

- Gradone Assemblato grip. 3x33x30
- Gradone Assemblato nat. 3x33x30

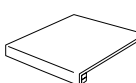

- Gradone Ang. Assemblato grip sx. 3x33x30
- Gradone Ang. Assemblato grip dx. 3x33x30
- Gradone Ang. Assemblato nat sx. 3x33x30
- Gradone Ang. Assemblato nat dx. 3x33x30

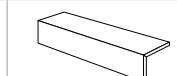
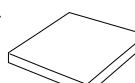

Elemento assemblato a "L" grip. 15x30x5

DISPONIBILE IN TUTTI I COLORI
Available in all colours - Disponible dans toutes les couleurs - In allen Farben erhältlich - Se comercializas en todos los colores



P.R Gris 30x60 grip

P.R Gris 30x60 nat.



PIERRE ROYALE

40x80^{16"x31,5"}. 30x60^{12"x24"}. 45x45^{18"x18"}. 20x80^{8"x31,5"}. 12x30^{4 3/4"x12"}.



P.R Gris 40x80 rett.
P.R Blanc 20x80 nat. rett. toreillo Blanc



P.R Gris 40x80 rett.
P.R Blanc 20x80 nat. rett. toreillo Blanc



P.R Gris 30x60 nat.
P.R Gris 45x45 . 12x30 . 20x80 . listello alluminio



P.R Beige 40x80
P.R Beige 30x60 . fascia Royale Beige . P.R Blanc muretto grip



QUARZ DESIGN

60x60^{24"x24"}.60x60 20 mm^{24"x24"}.30x60^{12"x24"}.15x60^{6"x24"}.30x30^{12"x12"}.15x15^{6"x6"}.

SHADE SPECTRUM			
Low <input type="checkbox"/>	Moderate <input checked="" type="checkbox"/>	High <input type="checkbox"/>	Random <input type="checkbox"/>

NATURALE	NATURALE	NATURALE	NATURALE
DIN 51130	DIN 51097	ASTM C1028	B.C.R.A.
		dry ≥ 0,60	dry ≥ 0,40
		wet ≥ 0,60	wet ≥ 0,40

FORMATO	SPESSORE	Pz	Mqx	Kgx		Mqx	Kgx
60x60	10	4	1,44	34,00	30	43,20	1020
30x60	10	6	1,08	23,50	40	43,20	950
15x60	10	12	1,08	23,50	55	59,40	1286
30x30	8,5	15	1,35	26,00	40	54,00	1040
15x15	8,5	15	1,35	26,00	40	54,00	1040
60x60	20	2	0,72	31,80	32	23,04	1040

QD BIANCO



60x60 nat. 60x60 nat. rett.



60x60 lappato rett.



Design Bianco 30x60 lappato rett.

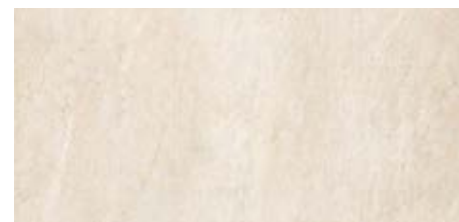

30x60 nat. 30x60 nat. rett.



30x60 lappato rett.



Muretto 30x60 nat.



15x60 nat. 15x60 nat. rett.



15x60 lappato rett.



30x30 nat.

30x30 nat. rett.



Mosaico 30x30 nat.

Listello Alluminio 0,6x60

Ang. Alluminio 0,6x0,6

QD ANTRACITE



60x60 nat. 60x60 nat. rett.
60x60 nat. 20mm 60x60 rett. 20mm



60x60 lappato rett.



30x60 nat. 30x60 nat. rett.



30x60 lappato rett.



Muretto 30x60 nat.



15x60 nat. 15x60 nat. rett.



15x60 lappato rett.



30x30 nat.

30x30 nat. rett.



15x15 nat.



Mosaico 30x30 nat.

Listello Alluminio 0,6x60

Ang. Alluminio 0,6x0,6

Pezzi SPECIALI

Special trims - Piezas especiales - Sonderstücke - Piezas especiales

● Gradino. nat. 30x30

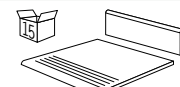

● Battiscopa. nat. 7,2x30



● Gradone Assemblato. nat. 3x33x30

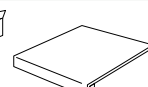

● Gradino. lappato rett. 30x30

● Battiscopa. lappato rett. 7,2x30

● Gradone Assemblato. lappato rett. 3x33x30

● Ang. Gradone Assemblato. nat. 3x33x33

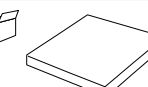

● Ang. Gradone Assemblato. lappato rett. 3x33x33

● Elemento a "L" monolitico 4,5x16,5x30

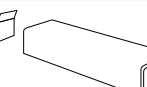

● DISPONIBILE IN TUTTI I COLORI
Available in all colours - Disponible dans toutes les couleurs - In allen Farben erhältlich - Se comercializas en todos los colores



QUARZ DESIGN

60x60^{24"x24"}.60x60 20 mm^{24"x24"}.30x60^{12"x24"}.15x60^{6"x24"}.30x30^{12"x12"}.15x15^{6"x6"}.

SHADE SPECTRUM			
<input type="checkbox"/>	Moderate <input type="checkbox"/>	High <input type="checkbox"/>	Random <input type="checkbox"/>

NATURALE	NATURALE	NATURALE	NATURALE
DIN 51130	DIN 51097	ASTM C1028	B.C.R.A.
R10	B	dry ≥ 0,60 wet ≥ 0,60	dry ≥ 0,40 wet ≥ 0,40

FORMATO	SPESSORE	Pz	Mqx	Kgx	Mqx	Kgx
60x60	10	4	1,44	34,00	30	43,20
30x60	10	6	1,08	23,50	40	43,20
15x60	10	12	1,08	23,50	55	59,40
30x30	8,5	15	1,35	26,00	40	54,00
15x15	8,5	15	1,35	26,00	40	54,00
60x60	20	2	0,72	31,80	32	23,04

QD FUMÈ



60x60 nat. **107 107** 60x60 nat. rett. **165 165**
60x60 nat. **20mm 184 184** 60x60 rett. **20mm 189 189**



60x60 lappato rett. **167 167**



30x60 nat. **85 85** 30x60 nat. rett. **151 151**



30x60 lappato rett. **159 159**



15x60 nat. **159 159** 15x60 nat. rett. **185 185**



15x60 lappato rett. **190 190**



30x30 nat. **46 46**



15x15 nat. **46 46**

30x30 nat. rett. **97 97**



Muretto 30x60 nat. **202 202**



Mosaico 30x30 nat. **127**

Listello Alluminio 0,6x60 **139**

Ang. Alluminio 0,6x0,6 **19**

QD GRIGIO



60x60 nat. **107 107** 60x60 nat. rett. **165 165**



60x60 lappato rett. **167 167**



30x60 nat. **85 85** 30x60 nat. rett. **151 151**



30x60 lappato rett. **159 159**

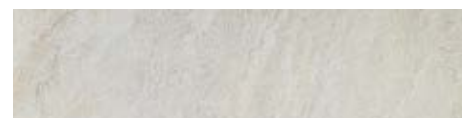

15x60 nat. **159 159** 15x60 nat. rett. **185 185**



15x60 lappato rett. **190 190**



30x30 nat. **46 46**

30x30 nat. rett. **97 97**



Design Grigio 30x60 lappato rett. **219**



Muretto 30x60 nat. **202 202**

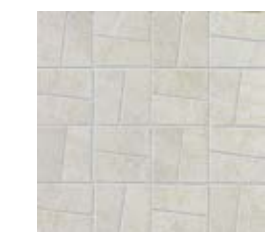

Mosaico 30x30 nat. **127**

Listello Alluminio 0,6x60 **139**

Ang. Alluminio 0,6x0,6 **19**

Pezzi SPECIALI

Special trims - Piezas especiales - Sonderstücke - Piezas especiales

● Gradino. nat. 30x30 **43**

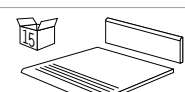

● Battiscopa. nat. 7,2x30 **3**



● Gradino. lappato rett. 30x30 **87**

● Battiscopa. lappato rett. 7,2x30 **12**

● Gradone Assemblato. nat. 3x33x30 **191**



● Gradone Assemblato. lappato rett. 3x33x30 **221**



● Ang. Gradone Assemblato. nat. 3x33x33 **233**



● Ang. Gradone Assemblato. lappato rett. 3x33x33 **251**

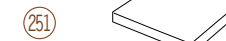

● Elemento a "L" monolitico 4,5x16,5x30 **123**

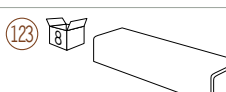

● DISPONIBILE IN TUTTI I COLORI
Available in all colours - Disponible dans toutes les couleurs - In allen Farben erhältlich - Se comercializas en todos los colores



QUARZ DESIGN

60x60^{24"x24"}.60x60 20 mm^{24"x24"}.30x60^{12"x24"}.15x60^{6"x24"}.30x30^{12"x12"}.15x15^{6"x6"}.

SHADE SPECTRUM			
Low <input type="checkbox"/>	Moderate <input type="checkbox"/>	High <input type="checkbox"/>	Random <input type="checkbox"/>

NATURALE	NATURALE	NATURALE	NATURALE
DIN 51130	DIN 51097	ASTM C1028	B.C.R.A.
R10	B	dry ≥ 0,60	dry ≥ 0,40
		wet ≥ 0,60	wet ≥ 0,40

FORMATO	SPESSORE	Pz x	Mqx	Kgx	Mqx	Kgx
60x60	10	4	1,44	34,00	30	43,20
30x60	10	6	1,08	23,50	40	43,20
15x60	10	12	1,08	23,50	55	59,40
30x30	8,5	15	1,35	26,00	40	54,00
15x15	8,5	15	1,35	26,00	40	54,00
60x60	20	2	0,72	31,80	32	23,04
						1020
						950
						1286
						1040
						1040
						1040

QD BEIGE



NF UPEC
U3 P3 E3 C2

60x60 nat. **107** **107** 60x60 nat. rett. **166** **166**
60x60 nat. **20mm** **184** **184** 60x60 rett. **20mm** **189** **189**



60x60 lappato rett. **167** **167**



Design Beige 30x60 lappato rett. **219**



NF UPEC
U3 P3 E3 C2

30x60 nat. **85** **85** 30x60 nat. rett. **151** **151**



30x60 lappato rett. **159** **159**



Muretto 30x60 nat. **202** **202**



15x60 nat. **159** **159** 15x60 nat. rett. **186** **186**



15x60 lappato rett. **190** **190**

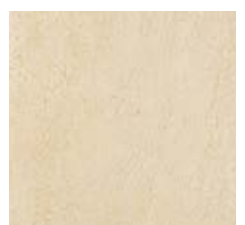

30x30 nat. **46** **46**

30x30 nat. rett. **97** **97**

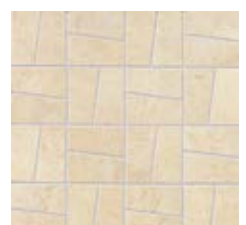

Mosaico 30x30 nat. **127**

Listello Alluminio 0,6x60 **139**

Ang. Alluminio 0,6x0,6 **19**



QD Beige 60x60 nat.
QD Beige muretto

Pezzi SPECIALI

Special trims - Piezas especiales - Sonderstücke - Piezas especiales

● Gradino. nat. 30x30 **43**

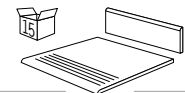

● Battiscopa. nat. 7,2x30 **3**

● Battiscopa. lappato rett. 7,2x30 **12**

● Gradone Assemblato. nat. 3x33x30 **191**

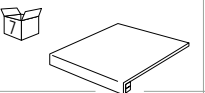

● Gradone Assemblato. lappato rett. 3x33x30 **221**

● Ang. Gradone Assemblato. nat. 3x33x33 **233**

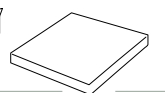

● Ang. Gradone Assemblato. lappato rett. 3x33x33 **251**

● Elemento a "L" monolitico 4,5x16,5x30 **123**

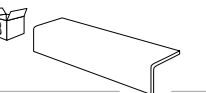

● DISPONIBILE IN TUTTI I COLORI
Available in all colours - Disponible dans toutes les couleurs - In allen Farben erhältlich - Se comercializas en todos los colores



QUARZ DESIGN

60x60^{24"x24"}.60x60 20 mm^{24"x24"}.30x60^{12"x24"}.15x60^{6"x24"}.30x30^{12"x12"}.15x15^{6"x6"}.



QD Fumè 30x60 nat. rett 15x60 nat. rett.



QD Bianco 60x60 nat. rett.



QD Antracite 60x60 nat. rett.

QUARZ DESIGN

60x60^{24"x24"}.60x60 20 mm^{24"x24"}.30x60^{12"x24"}.15x60^{6"x24"}.30x30^{12"x12"}.15x15^{6"x6"}.



QD Grigio 60x60 nat. rett.
QD Grigio 15x60 nat. rett. mosaico



QD Grigio 15x60 nat. rett.



QD Beige 30x60 lapp. rett. Design Beige 30x60 lapp. rett. listello alluminio



SHADE

80x80_{31,5"x31,5"}.40x80_{16"x31,5"}.40x80 20 mm_{16"x31,5"}.60x60_{24"x24"}.30x60_{12"x24"}.30x30_{12"x12"}

SHADE SPECTRUM

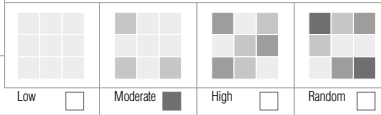

DIN 51130

DIN 51097

ASTM C1028

B.C.R.A.

D.C.O.F.

R9

B

dry ≥ 0,60
wet ≥ 0,60

dry ≥ 0,40
wet ≥ 0,40

wet ≥ 0,42

20MM

DIN 51130

DIN 51097

B.C.R.A.

D.C.O.F.

R11

C

dry ≥ 0,40
wet ≥ 0,40

wet ≥ 0,42

SH GHIACCIO



60x60 nat.



40x80 decorato rett.

179 179



esagona 10 30x30 nat.

202 202



esagona CARPET 30x30 nat.

230 230



muretto 30x60 nat.

200 200



80x80 rett.

175 175



40x80 nat.

125 125

40x80 nat. rett.

161 161



40x80 nat. 20mm

184 184

40x80 rett. 20mm

189 189



60x60 nat.

107 107



30x60 nat.

85 85



30x30 nat.

64 64

SH NOTTE



60x60 nat.



40x80 decorato rett.

179 179



esagona 10 30x30 nat.

202 202



esagona CARPET 30x30 nat.

230 230



muretto 30x60 nat.

200 200



80x80 rett.

175 175



40x80 nat.

125 125

40x80 nat. rett.

161 161



40x80 nat. 20mm

184 184

40x80 rett. 20mm

189 189



60x60 nat.

107 107



30x60 nat.

85 85



30x30 nat.

64 64

FORMATO	SPESSORE	Pz x	Mqx	Kgx	Mqx	Kgx
80x80	10,3	2	1,28	29,40	40	1176,00
40x80	10,3	3	0,96	22,00	28	618,00
60x60	10,3	4	1,44	31,80	30	954,00
30x60	10,3	6	1,08	23,50	40	940,00
30x30	8,5	15	1,35	25,00	40	1000,00
40x80	20	2	0,64	30,00	24	720,00
30x30 CARPET	10,3	12	1,08	24,00	40	980,00

Pezzi SPECIALI

Special trims - Pieces especiales - Sonderstücke - Piezas especiales

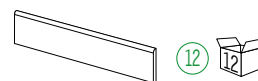

Battiscopa 7,5x60

12

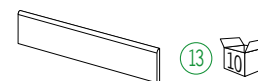

Battiscopa 7,5x80

13

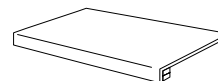

Gradone Assemblato. 3x33x60 nat.

233

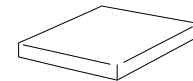

Ang. Gradone Assemblato. 3x33x33 nat.

227

20MM

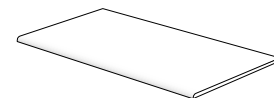

Gradone Lineare nat. 2x40x80

233

Gradone Lineare rett. 2x40x80

243

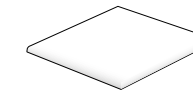

Gradone Angolare nat. 2x40x40

233

Gradone Angolare rett. 2x40x40

243

DISPONIBILE IN TUTTI I COLORI
Available in all colours - Disponible dans toutes les couleurs - In allen Farben erhältlich - Se comercializas en todos los colores



SHADE

80x80_{31,5"x31,5"}.40x80_{16"x31,5"}. 40x80 20 mm _{16"x31,5"}60x60_{24"x24"}.30x60_{12"x24"}.30x30_{12"x12"}

SH SABBIA

SHADE SPECTRUM

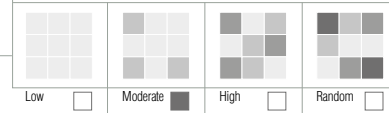

DIN 51130



DIN 51097



ASTM C1028

dry ≥ 0,60
wet ≥ 0,60

B.C.R.A.

dry ≥ 0,40
wet ≥ 0,40

D.C.O.F.

wet ≥ 0,42

20MM

DIN 51130



DIN 51097



B.C.R.A.

dry ≥ 0,40
wet ≥ 0,40

D.C.O.F.

wet ≥ 0,42

SH TERRA



60x60 nat.



40x80 nat.
40x80 nat. rett.



60x60 nat.

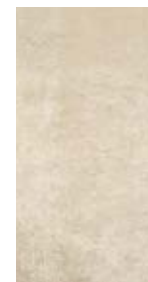

30x60 nat.

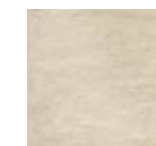

30x30 nat.



40x80 decorato rett.



esagona 10 30x30 nat.



esagona CARPET 30x30 nat.



muretto 30x60 nat.



60x60 nat.



40x80 nat.
40x80 nat. rett.



40x80 nat. 20mm



60x60 nat.



30x60 nat.

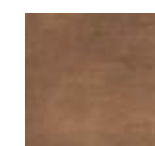

30x30 nat.



40x80 decorato rett.



esagona 10 30x30 nat.



esagona CARPET 30x30 nat.



muretto 30x60 nat.

FORMATO	SPESSORE	Pz	Mqx	Kgx		Mqx	Kgx
80x80	10,3	2	1,28	29,40	40	51,20	1176,00
40x80	10,3	3	0,96	22,00	28	26,88	618,00
60x60	10,3	4	1,44	31,80	30	43,20	954,00
30x60	10,3	6	1,08	23,50	40	43,20	940,00
30x30	8,5	15	1,35	25,00	40	54,00	1000,00
40x80	20	2	0,64	30,00	24	15,36	720,00
30x30 CARPET	10,3	12	1,08	24,00	40	43,20	980,00

Pezzi SPECIALI

Special trims - Piezas especiales - Sonderstücke - Piezas especiales

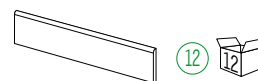

● Battiscopa 7,5x60

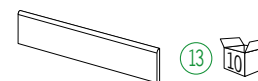

● Battiscopa 7,5x80

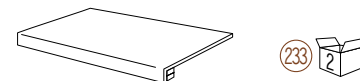

● Gradone Assemblato. 3x33x60 nat.

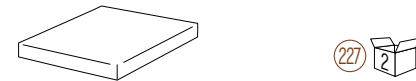

● Ang. Gradone Assemblato. 3x33x33 nat.

20MM

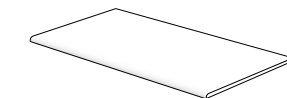

● Gradone Lineare nat. 2x40x80
● Gradone Lineare rett. 2x40x80

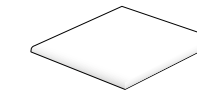

● Gradone Angolare nat. 2x40x40
● Gradone Angolare rett. 2x40x40

● DISPONIBILE IN TUTTI I COLORI
Available in all colours - Disponible dans toutes les couleurs - In allen Farben erhältlich - Se comercializas en todos los colores



SHADE

30x30 12"x12"

SH CARPET 30

SHADE SPECTRUM			
Low <input type="checkbox"/>	Moderate <input checked="" type="checkbox"/>	High <input type="checkbox"/>	Random <input type="checkbox"/>

DIN 51130	DIN 51097	ASTM C1028	B.C.R.A.	D.C.O.F.
R9	B	dry ≥ 0,60 wet ≥ 0,60	dry ≥ 0,40 wet ≥ 0,40	wet ≥ 0,42

DIN 51130	DIN 51097	B.C.R.A.	D.C.O.F.
R11	C	dry ≥ 0,40 wet ≥ 0,40	wet ≥ 0,42



SH CARPET 30 nat.



SH Carpet 30 nat. - SH Sabbia 30x60 nat.



SH Ghiaccio 40x80 nat. - SH Carpet 30 nat. - SH Ghiaccio esagona Carpet



SHADE

80x80_{31,5"x31,5"}.40x80_{16"x31,5"}. 40x80 20 mm_{16"x31,5"}60x60_{24"x24"}.30x60_{12"x24"}.30x30_{12"x12"}



SH Sabbia muretto 30x60 nat.



SH Terra 40x80 nat. - Sh Carpet 30x30 - SH Sabbia muretto 30x60 nat.



SHADE

80x80_{31,5"x31,5"}. 40x80_{16"x31,5"}. 40x80 20 mm_{16"x31,5"} 60x60_{24"x24"}. 30x60_{12"x24"}. 30x30_{12"x12"}



IN: SH Ghiaccio 80x80 rett.



SH Notte 80x80 rett. - Wallpaper SHADE COLD



TAILORMADE

40x80^{16"x32"}.60x60^{24"x24"}.30x60^{12"x24"}.30x30^{12"x12"}.

SHADE SPECTRUM			
Low <input type="checkbox"/>	Moderate <input checked="" type="checkbox"/>	High <input type="checkbox"/>	Random <input type="checkbox"/>

NATURALE	NATURALE	NATURALE	NATURALE
DIN 51130	DIN 51097	ASTM C1028	B.C.R.A.
		dry ≥ 0,80 wet ≥ 0,60	dry ≥ 0,80 wet ≥ 0,70

FORMATO	SPESSORE	Pzx	Mqx	Kgx		Mqx	Kgx
40x80	10,3	3	0,96	22,00	28	26,88	618,00
60x60	10,3	4	1,44	31,80	32	46,08	1040,00
30x60	10,3	6	1,08	23,50	40	43,20	940,00
30x30	10,3	12	1,08	24,00	40	43,20	980,00

TM BIANCO



40x80 nat.
40x80 lap. rett.



60x60 nat.
60x60 lap. rett.



30x30 nat.



30x60 nat.
30x60 lap. rett.



Mosaico 30x30 (5x5)



Ice Fascia 5,5x60



Ice Torello 4x60



Ice Ang. Torello 4x4



Ice Matita 1x60



Ice Ang. Matita 1x1



TMbianco Decoro 30x60 lap. rett.



TMbianco Wave 30x60 rett.



Listello Alluminio 1x80

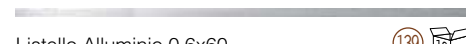

Listello Alluminio 0,6x60



Fascia Metallo 1x30



TM BEIGE



40x80 nat.
40x80 lap. rett.



60x60 nat.
60x60 lap. rett.

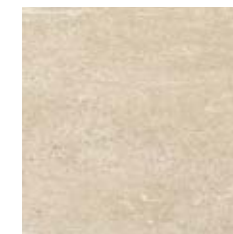

30x30 nat.



30x60 nat.
30x60 lap. rett.

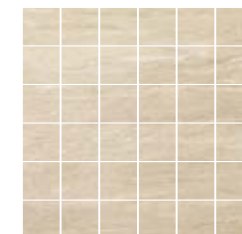

Mosaico 30x30 (5x5)



Coffee Fascia 5,5x60



Coffee Torello 4x60



Coffee Ang. Torello 4x4



Coffee Matita 1x60



TMbeige Decoro 30x60 lap. rett.



TMbeige Wave 30x60 rett.



Listello Alluminio 1x80



Listello Alluminio 0,6x60



Fascia Metallo 1x30



Pezzi SPECIALI

Special trims - Piezas especiales - Sonderstücke - Piezas especiales

• Battiscopa 10x60



12

• Gradone Lineare 3x30x33

173

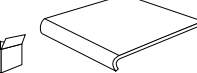

• Gradone Angolare Lineare 3x33x33

221

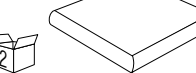

• DISPONIBILE IN TUTTI I COLORI

Available in all colours - Disponible dans toutes les couleurs - In allen Farben erhältlich - Se comercializas en todos los colores



TAILORMADE

40x80^{16"x32"}.60x60^{24"x24"}.30x60^{12"x24"}.30x30^{12"x12"}.

SHADE SPECTRUM			
Low <input type="checkbox"/>	Moderate <input checked="" type="checkbox"/>	High <input type="checkbox"/>	Random <input type="checkbox"/>

NATURALE	NATURALE	NATURALE	NATURALE
DIN 51130	DIN 51097	ASTM C1028	B.C.R.A.
		dry ≥ 0,60 wet ≥ 0,60	dry ≥ 0,40 wet ≥ 0,40

FORMATO	SPESSORE	Pz	Mqx	Kgx		Mqx	Kgx
40x80	10,3	3	0,96	22,00	28	26,88	618,00
60x60	10,3	4	1,44	31,80	32	46,08	1040,00
30x60	10,3	6	1,08	23,50	40	43,20	940,00
30x30	10,3	12	1,08	24,00	40	43,20	980,00

TM GRIGIO



40x80 nat.
40x80 lap. rett.



60x60 nat.
60x60 lap. rett.



30x30 nat.



30x60 nat.
30x60 lap. rett.

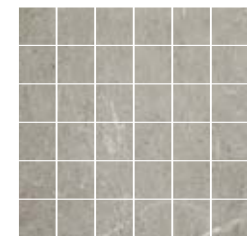

Mosaico 30x30 (5x5)



Ice Fascia 5,5x60



Ice Torello 4x60



Ice Ang. Torello 4x4



Ice Matita 1x60

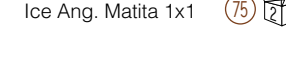

Ice Ang. Matita 1x1



TMgrigio Decoro 30x60 lap. rett.



TMgrigio Wave 30x60 rett.



Listello Alluminio 1x80



Listello Alluminio 0,6x60



Fascia Metallo 1x30

TM NERO



40x80 nat.
40x80 lap. rett.



60x60 nat.
60x60 lap. rett.



30x30 nat.



30x60 nat.
30x60 lap. rett.

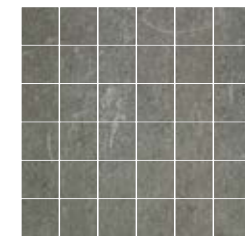

Mosaico 30x30 (5x5)



Ice Fascia 5,5x60



Ice Torello 4x60



Ice Ang. Torello 4x4



Ice Matita 1x60



Ice Ang. Matita 1x1

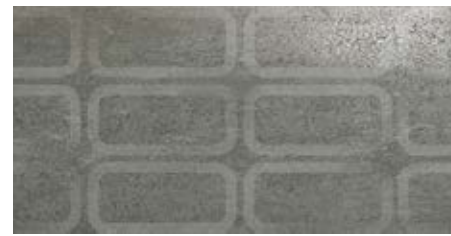

TMnero Decoro 30x60 lap. rett.



Listello Alluminio 0,6x60



Listello Alluminio 1x80



Fascia Metallo 1x30

Pezzi SPECIALI

Special trims - Piezas especiales - Sonderstücke - Piezas especiales

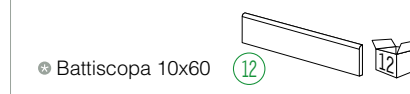

Battiscopa 10x60



Gradone Lineare 3x30x33



Gradone Angolare Lineare 3x33x33

DISPONIBILE IN TUTTI I COLORI
Available in all colours - Disponible dans toutes les couleurs - In allen Farben erhältlich - Se comercializas en todos los colores



TAILORMADE

40x80^{16"x32"}.60x60^{24"x24"}.30x60^{12"x24"}.30x30^{12"x12"}.

SHADE SPECTRUM

Low Moderate High Random

NATURALE	NATURALE	NATURALE	NATURALE
DIN 51130	DIN 51097	ASTM C1028	B.C.R.A.
R9	B	dry ≥ 0,60 wet ≥ 0,60	dry ≥ 0,40 wet ≥ 0,40

FORMATO	SPESSORE	Pzx	Mqx	Kgx	Mqx	Kgx
40x80	10,3	3	0,96	22,00	28	26,88
60x60	10,3	4	1,44	31,80	32	46,08
30x60	10,3	6	1,08	23,50	40	43,20
30x30	10,3	12	1,08	24,00	40	43,20

TM NOCE



40x80 nat.
40x80 lap. rett.



60x60 nat.
60x60 lap. rett.



30x60 nat.
30x60 lap. rett.

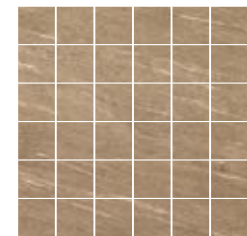

Mosaico 30x30 (5x5)



30x30 nat.



Coffee Fascia 5,5x60



Coffee Torello 4x60



Coffee Ang. Torello 4x4



Coffee Matita 1x60



Coffee Ang. Matita 1x1



Listello Alluminio 1x80



Listello Alluminio 0,6x60



Fascia Metallo 1x30



Pezzi SPECIALI

Special trims - Piezas especiales - Sonderstücke - Piezas especiales

● Battiscopa 10x60

● Gradone Lineare 3x30x33

● Gradone Angolare Lineare 3x33x33

● DISPONIBILE IN TUTTI I COLORI
Available in all colours - Disponible dans toutes les couleurs - In allen Farben erhältlich - Se comercializas en todos los colores



TM Noce 40x80 nat.

TM Noce 40x80 lapp. rett.



TAILORMADE

40x80^{16"x32"}.60x60^{24"x24"}.30x60^{12"x24"}.30x30^{12"x12"}.



TM Grigio 40x80 nat.
TM Bianco decoro 30x60 lapp. rett.



TM Grigio 40x80 lapp. rett.
TM Bianco Wave 30x60 rett. TM Grigio Wave 30x60 rett. TM Grigio decoro 30x60 lapp. rett.



TAILORMADE

40x80^{16"x32"}.60x60^{24"x24"}.30x60^{12"x24"}.30x30^{12"x12"}.



TM Beige 30x60 nat.



TM Beige 60x60 lapp. rett.



TM Nero 40x80 nat.



TM Nero 60x60 nat.



V.360

80x80^{32"x32"}.40x80^{16"x32"}.40x80 20 mm^{16"x31,5"}.20x80^{8"x32"}.60x60^{24"x24"}.30x60^{12"x24"}.30x30^{12"x12"}.

SHADE SPECTRUM			
Low <input type="checkbox"/>	Moderate <input type="checkbox"/>	High <input type="checkbox"/>	Random <input type="checkbox"/>

NATURALE					GRIP	
DIN 51130	DIN 51097	ASTM C1028	B.C.R.A.	D.C.O.F.	DIN 51130	DIN 51097
		dry > 0,60 wet > 0,60	dry > 0,40 wet > 0,40	wet ≥ 0,42		

FORMATO	SPESSORE	Pz x	Mqx	Kgx	Mqx	Kgx
80x80	10,3	2	1,28	29,40	40	51,20
40x80	10,3	3	0,96	22,00	28	26,88
20x80	10,3	6	0,96	22,00	28	26,88
60x60	10,3	4	1,44	31,80	32	46,08
30x60	10,3	6	1,08	23,50	40	43,20
30x30	10,3	12	1,08	24,00	40	47,52
40x80	20	2	0,64	30,00	24	15,36

V.360 WHITE

V.360 GREY

V.360 BLACK



80x80 rett.



60x60 nat.
60x60 nat./rett.



80x80 rett.



60x60 nat.
60x60 nat./rett.



80x80 rett.

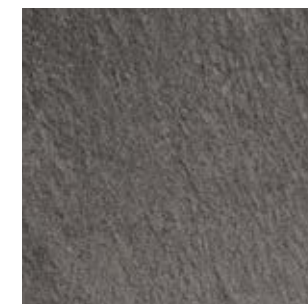

60x60 nat.
60x60 nat./rett.



40x80 nat.
40x80 nat./rett.
40x80 20 mm nat.
40x80 20 mm rett.

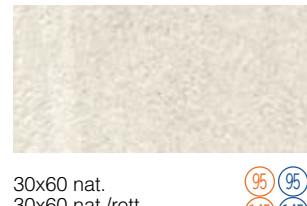

30x60 nat.
30x60 nat./rett.
30x60 grip/nat.



40x80 nat.
40x80 nat./rett.
40x80 20 mm nat.
40x80 20 mm rett.

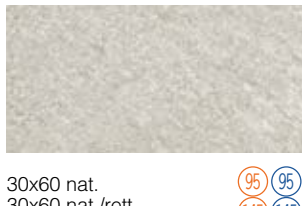

30x60 nat.
30x60 nat./rett.
30x60 grip/nat.



40x80 nat.
40x80 nat./rett.
40x80 20 mm nat.
40x80 20 mm rett.

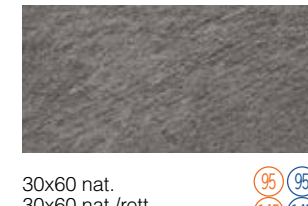

30x60 nat.
30x60 nat./rett.
30x60 grip/nat.

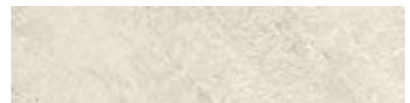

20x80 rett.

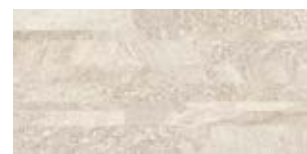

brick 30x60 rett.



20x80 rett.



brick 30x60 rett.



20x80 rett.



brick 30x60 rett.



30x30 nat.



mosaico 30x30 nat.
(tessera 5x5)
mosaico 30x30 grip
(tessera 5x5)



30x30 nat.

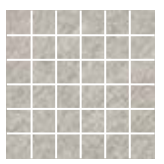

mosaico 30x30 nat.
(tessera 5x5)
mosaico 30x30 grip
(tessera 5x5)



30x30 nat.

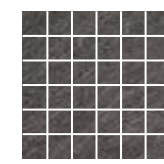

mosaico 30x30 nat.
(tessera 5x5)
mosaico 30x30 grip
(tessera 5x5)



V.360 Black 80x80 rett.
brick 30x60 rett.

Pezzi SPECIALI

Special trims - Piezas especiales - Sonderstücke - Piezas especiales

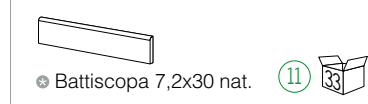

Battiscopa 7,2x30 nat.

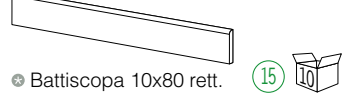

Battiscopa 10x80 rett.



Gradone Assemblato. 33x60 nat.



Gradone ang. Assemblato 33x33 nat.

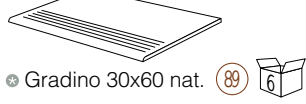

Gradino 30x60 nat.



Elemento angolare monolitico 60x5x5 (grip)

DISPONIBILE IN TUTTI I COLORI
Available in all colours - Disponible dans toutes les couleurs - In allen Farben erhältlich - Se comercializas en todos los colores



V.360

80x80_{32"x32"}.40x80_{16"x32"}.40x80 20 mm_{16"x31,5"}.20x80_{8"x32"}.60x60_{24"x24"}.30x60_{12"x24"}.30x30_{12"x12"}.

V.360 White 30x60 nat.
brick 30x60 rett.



V.360 White 30x60 nat.
brick 30x60 rett.



V.360 White 60x60 nat.



V.360

80x80_{32"x32"}.40x80_{16"x32"}.40x80 20 mm _{16"x31,5"}.20x80_{8"x32"}.60x60_{24"x24"}.30x60_{12"x24"}.30x30_{12"x12"}.

V.360 White 80x80 nat. rett.
V.360 White 40x80 nat. rett. 20x80 nat. rett. V.360 Grey 20x80 nat. rett.





V.360

80x80^{32"x32"}.40x80^{16"x32"}.40x80 20 mm ^{16"x31,5"}.20x80^{8"x32"}.60x60^{24"x24"}.30x60^{12"x24"}.30x30^{12"x12"}.



V.360 Grey 80x80 rett.



V.360 Brick Grey 30x60 rett.



V.360 Grey 60x60 nat. rett.



V.360

80x80^{32"x32"}.40x80^{16"x32"}.40x80 20 mm^{16"x31,5"}.20x80^{8"x32"}.60x60^{24"x24"}.30x60^{12"x24"}.30x30^{12"x12"}.



V.360 Grey 30x60 grip . elemento angolare monolitico



V.360 Black 30x60 nat. rett. mosaico



VILLA IMPERIALE

60x60^{24"x24"}. 30x60^{12"x24"}. 15x60^{6"x24"}.

VILLA BIANCA



60x60
60x60 lapp. rett.

127 127
167 167



15x60

159 159

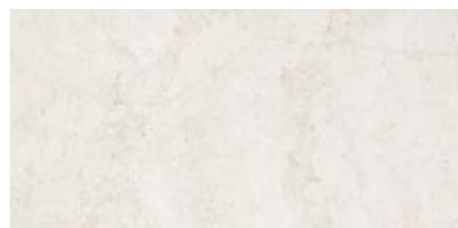

30x60

97 97



Inserto Villa Bianca 30x60

169 2



Mosaico Villa Bianca
(30x30) 5x5

230 230 5

Mosaico Villa Bianca
(30x30) 5x5 lapp. rett.

230 230 5



Mosaico Rombi Villa Bianca
(30x30) 15x7,5

230 230 5



Fascia Mix 5x30

127 6



Tozz. Fascia Mix 5x5

63 4



Torello Villa Bianca 5x30

151 6



Ang. Torello Villa Bianca
5x3

2 123



Muretto Multispessore Villa Imperiale 30x60

177 5



Listello Villa Bianca 7x30

99 6



Fascia Villa Bianca 8x60

163 6



Ang. Fascia
Villa Bianca 8x8

51 4



Listello Noce 6,5x60

87 6



Tozz. Noce 6,5x6,5

23 4

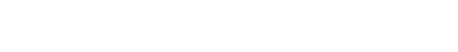

Listello Lux 0,6x60
(solo rivestimento - only wall)

151 10



Listello Alluminio
0,6x60

139 10



Ang. Alluminio
0,6x0,6

19 4

Pezzi SPECIALI

Special trims - Pieces especiales - Sonderstücke - Piezas especiales



Battiscopa NAT. 7,2x30

11 3

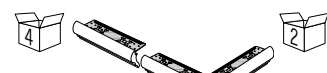

Angolo Profilo Gradino. 4x4,5x33

207 4

DISPONIBILE IN TUTTI I COLORI

Available in all colours - Disponible dans toutes les couleurs - In allen Farben erhältlich - Se comercializas en todos los colores

SHADE SPECTRUM			
Low <input type="checkbox"/>	Moderate <input type="checkbox"/>	High <input type="checkbox"/>	Random <input checked="" type="checkbox"/>

NATURALE	NATURALE	NATURALE
DIN 51130	DIN 51097	B.C.R.A.
		dry ≥ 0,60
		wet ≥ 0,50

FORMATO	SPESSORE	Pzx	Mqx	Kgx	Mqx	Kgx
60x60	10,3	4	1,44	31,80	32	46,08
30x60	10,3	6	1,08	23,50	40	43,20
15x60	10,3	12	1,08	23,50	55	59,40

Villa Bianca 30x60
listello Lux
listello Villa Bianca
mosaico Rombi





VILLA IMPERIALE

60x60^{24"x24"}.30x60^{12"x24"}.15x60^{6"x24"}.

SHADE SPECTRUM			
Low <input type="checkbox"/>	Moderate <input type="checkbox"/>	High <input type="checkbox"/>	Random <input checked="" type="checkbox"/>

NATURALE	NATURALE	NATURALE
DIN 51130	DIN 51097	B.C.R.A.
		dry ≥ 0,40
		wet ≥ 0,40

FORMATO	SPESSORE	Pz x	Mqx	Kgx		Mqx	Kgx
60x60	10,3	4	1,44	31,80	32	46,08	1040
30x60	10,3	6	1,08	23,50	40	43,20	950
15x60	10,3	12	1,08	23,50	55	59,40	1286

VILLA BEIGE



60x60
60x60 lapp. rett.



15x60



30x60



Inserto Villa Beige 30x60



Mosaico Villa Beige (30x30) 5x5

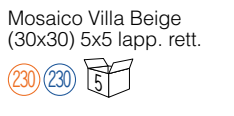

Mosaico Villa Beige (30x30) 5x5 lapp. rett.



Mosaico Rombi Villa Beige (30x30) 15x7,5



Fascia Mix 5x30

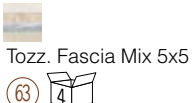

Tozz. Fascia Mix 5x5



Torello Villa Bianca 5x30

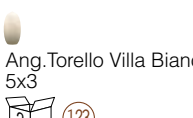

Ang. Torello Villa Bianca 5x3



Muretto Multispessore Villa Imperiale 30x60



Listello Villa Bianca 7x30

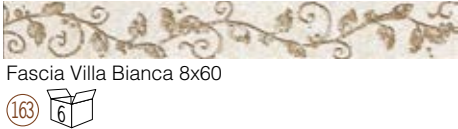

Fascia Villa Bianca 8x60



Ang. Fascia Villa Bianca 8x8



Listello Noce 6,5x60



Tozz. Noce 6,5x6,5

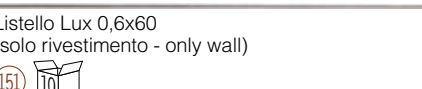

Listello Lux 0,6x60 (solo rivestimento - only wall)



Listello Alluminio 0,6x60

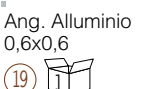

Ang. Alluminio 0,6x0,6

Pezzi SPECIALI

Special trims - Pieces especiales - Sonderstücke - Piezas especiales

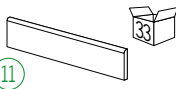

● Battiscopa NAT. 7,2x30

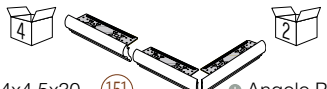

● Profilo Gradino. 4x4,5x30 ● Angolo Profilo Gradino. 4x4,5x33

● DISPONIBILE IN TUTTI I COLORI
Available in all colours - Disponible dans toutes les couleurs - In allen Farben erhältlich - Se comercializas en todos los colores





VILLA IMPERIALE

60x60^{24"x24"}.30x60^{12"x24"}.15x60^{6"x24"}.

SHADE SPECTRUM

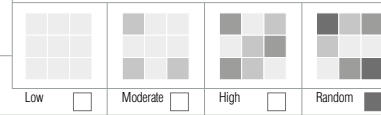

NATURALE	NATURALE	NATURALE
DIN 51130	DIN 51097	B.C.R.A.
R10	A	dry ≥ 0,60
		wet ≥ 0,50

FORMATO	SPESSORE	Pz x	Mqx	Kgx	Mqx	Kgx
60x60	10,3	4	1,44	31,80	32	46,08
30x60	10,3	6	1,08	23,50	40	43,20
15x60	10,3	12	1,08	23,50	55	59,40

VILLA NOCE



60x60
60x60 lapp. rett.

127 127
167 167



15x60

159 159



30x60

97 97



Inserto Villa Noce 30x60

169 2



Mosaico Villa Noce
(30x30) 5x5

230 230 5

Mosaico Villa Noce
(30x30) 5x5 lapp. rett.

230 230 5



Mosaico Rombi Villa Noce
(30x30) 15x7,5

230 230 5



Fascia Mix 5x30

127 6



Tozz. Fascia Mix 5x5

63 4



Torello Villa Noce 5x30

151 6



Ang. Torello Villa Noce
5x3

2 123



Muretto Multispessore Villa Imperiale 30x60

177 5



Listello Villa Noce 7x30

99 6



Fascia Villa Noce 8x60

163 6



Ang. Fascia
Villa Noce 8x8

51 4



Listello Noce 6,5x60

87 6



Tozz. Noce 6,5x6,5

23 4



Listello Lux 0,6x60
(solo rivestimento - only wall)

151 10



Listello Alluminio
0,6x60

139 10



Ang. Alluminio
0,6x0,6

19 4

Pezzi SPECIALI

Special trims - Sonderstücke - Piezas especiales - Piezas especiales



Battiscopa NAT. 7,2x30

11 3



Angolo Profilo Gradino. 4x4,5x33

151 2

207 4

DISPONIBILE IN TUTTI I COLORI
Available in all colours - In allen Farben erhältlich - Disponible dans toutes les couleurs - Se comercializas en todos los colores



Villa Noce 60x60 lapp. rett.

20 MM è la gamma di prodotti Pastorelli in gres porcellanato a due centimetri di spessore, per assicurare estetica, affidabilità e sicurezza alle pavimentazioni esterne.

Con le collezioni 20 MM si possono adottare diversi metodi di posa: a secco su erba, ghiaia e sabbia, incollata su massetto e sopraelevata. Questa versatilità ne consente l'applicazione in spazi outdoor sia pubblici sia privati, come giardini, terrazze, balconi, piscine, aree pedonali o carrabili.

20 MM is Pastorelli's offer of porcelain stoneware products with 20mm thickness, able to ensure elegance, reliability and safety to external floorings. 20 MM collections can be installed in many different ways: directly on the grass, gravel or sand, glued on the screed or as a raised floor.

20 MM strong versatility allows every kind of application, in outdoor spaces both public and private, like gardens, patios, terraces, pools, pedestrian or vehicle walks.

20 MM est la gamme des produits Pastorelli en grés céram en 20 MM d'épaisseur qui souhaite assurer esthétique, confiance et sécurité aux carrelages extérieurs.

On peut adopter différents méthodes de pose avec les collections en 20 MM : pose sur pelouse, gravier et sable, pose traditionnelle ou surélevée. Cette versatilité permet son application en ambiances extérieures soit publiques soit privées, comme jardins, terrasses, balcon, piscines, zones piétonnes ou charretières

20 MM ist die neue Produktgruppe von Pastorelli in Feinsteinzeug, um Ästhetik, Zuverlässigkeit und Sicherheit für externe Beläge zu gewährleisten. Mit unseren Serien in 20 MM kann man verschiedene Verlegungsarten anwenden: Festverlegung, Sand, Split und Stelzlager.

Verschiedene Anwendungsbereiche sind möglich: Öffentlichkeit, privater Bereich, Garten, Terrasse, Balkone, Schwimmbäder, Fußgängerzone oder andere stark belastete Bereiche.

20MM

pastorelli



20MM

 pastorelli



POSA TRADIZIONALE
Standard laying. Herkömmliche
Verlegungsart. Pose traditionnelle



POSA SOPRAELEVATA
Raised laying .
Verlegung auf Stelzlägern .
Pose surélevée



POSA SU ERBA
Laying on grass. Verlegung auf Wiese.
Pose sur pelouse



POSA SU GHIAIA O SABBIA
Laying on gravel or sand. Verlegung auf
Kies-oder Sand-Bett
Pose sur sable ou sur gravier

20MM



MADERA Rovere 40x80



DELTA Grigio 60x60

POSA SU ERBA

INSTALLATION ON GRASS.
POSE SUR HERBE.
VERLEGUNG AUF GRAS.

Consigliata versione con bordi naturali
Natural edges version recommended
Conseillée en version avec bords naturels
Es wird die Version mit natürlichen Rändern empfohlen

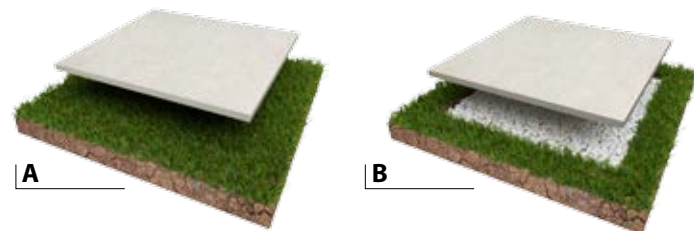
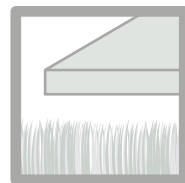

La posa su erba può essere eseguita in due modi:

- A) Diretta, cioè appoggiando direttamente la piastrella sul manto erboso, con una fuga di 4/5cm assicurandosi che in questo piccolo canale l'erba possa crescere correttamente; in questo caso, estremamente semplice e veloce, si avrà un risultato di buona durata ma dipendente dai movimenti del terreno.
- B) Per una maggiore stabilità si può procedere preparando il fondo con uno strato di 5 cm di ghiaia (diametro 4/8 mm) o sabbia poi adagiare 20MM a secco.

Installation on grass can be done in one of two methods:

- A) Direct, that is laying the tile directly on the grass, with a tile gap of 4 or 5 cm, ensuring that the grass can still grow in this narrow channel; in this case, installation is extremely quick and easy, the end result will be long-lasting, but will be dependent on soil movement.
- B) For greater stability, the ground can be covered with a 5 cm layer of gravel (4/8 mm diameter) or sand, then dry-lay 20MM.

La pose sur herbe peut être effectuée de deux manières:

- A) A) directe, c'est-à-dire en posant directement la dalle sur la pelouse, avec un joint de 4/5 cm en s'assurant que dans ce petit canal, l'herbe puisse pousser correctement; dans ce cas, extrêmement facile et rapide, il sera obtenu un résultat de longue durée mais dépendant des mouvements du terrain.
- B) B) Pour une plus grande stabilité, il est possible de procéder en préparant le fond avec une couche de 5 cm de gravier (d'un diamètre de 4/8 mm) ou de sable puis de poser 20MM à sec.

Die Verlegung auf Gras kann auf zwei Arten erfolgen:

- A) Direkte Verlegung, d.h die Fliese wird direkt auf den Rasen aufgelegt, mit einer Fuge von 4/5 cm, sodass der Rasen in diesem kleinen Kanal korrekt wachsen kann; in diesem Fall wird man einfach und schnell ein sehr dauerhaftes Ergebnis erreichen, das aber von den Bewegungen der Erde abhängig ist.
- B) Um eine höhere Stabilität zu haben, kann der Grund mit einer 5 cm breiten Schicht aus Kies (4/8 mm Durchmesser) oder aus Sand vorbereitet werden und dann 20MM trocken verlegt werden.

POSA SU GHIAIA

INSTALLATION ON GRAVEL.
POSE SUR GRAVIER.
VERLEGUNG AUF KIES.

Consigliata versione con bordi naturali
Natural edges version recommended
Conseillée en version avec bords naturels
Es wird die Version mit natürlichen Rändern empfohlen

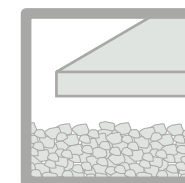

Ideale su superfici prevalentemente in piano, preparare il fondo (10/15 cm) con uno strato di pietrisco fine poi sopra stendere uno strato di ghiaia (diametro 4/8 mm), livellare con un rastrello verificando il livello con una staggia e livella poi posare 20MM a secco.

Suitable for mainly flat surfaces, prepare the ground (10/15 cm) with a layer of finely crushed stone, then add a layer of gravel (4/8 mm diameter), level with a rake, ensuring it is level with a straight edge and a level, then dry-lay 20MM.

Idéale sur des surfaces principalement plates, préparer le fond (10/15 cm) avec une couche de cailloutis fin puis étendre par-dessus une couche de gravier (d'un diamètre de 4/8 mm), niveler avec un râtelier en contrôlant le niveau au moyen d'une règle et d'un niveau puis poser 20MM à sec.

Ideal auf vorwiegend waagrechten Oberflächen, den Grund (10/15 cm) mit feinem Schotter vorbereiten und dann eine Schicht Kies (4/8 mm Durchmesser) drüber legen, mit einer Harke nivellieren und dabei die Bodenhöhe mit Libelle und Nivellierlatte prüfen und dann 20MM trocken verlegen.



POSA SU SABBIA

INSTALLATION ON SAND.
POSE SUR SABLE.
VERLEGUNG AUF SAND.

Consigliata versione con bordi naturali
Natural edges version recommended
Conseillée en version avec bords naturels
Es wird die Version mit natürlichen Rändern empfohlen

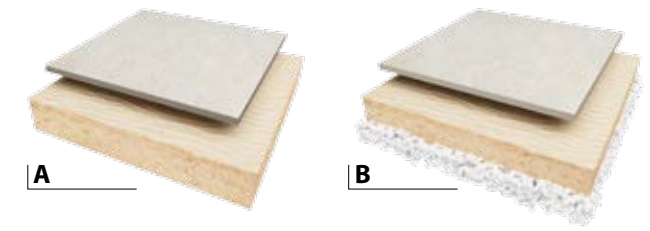

La posa su sabbia può essere eseguita in due modi:

- A) Direttamente sulla sabbia, dopo aver livellato la superficie con una staggia o tavola di legno.
- B) Per una maggiore durata e stabilità della posa preparare un sottofondo con uno strato di circa 15 cm di pietrisco fine, pressarlo livellandolo poi riportare uno strato di circa 5 cm di sabbia livellandola con una staggia o tavola di legno poi posare a secco 20MM.

Installation on sand can be done in one of two methods:

- A) Directly on the sand, after levelling the surface with a straight edge or wooden board.
- B) For greater stability and a long-lasting installation, prepare a sub-floor with a layer of about 15 cm of finely crushed stone, tamp it down and level it, then add a layer of about 5 cm of sand levelling it with a straight edge or wooden board, then dry-lay 20MM.

La pose sur sable peut être effectuée de deux manières:

- A) Directement sur le sable, après avoir nivelé la surface avec une règle ou une barre en bois.
- B) Pour une plus longue durée de vie et stabilité de la pose, préparer une base avec une couche d'environ 15 cm de cailloutis fin, le compresser tout en le mettant à niveau puis remettre une couche de sable d'environ 5 cm. La niveler avec une règle ou une barre en bois puis poser 20MM à sec.

Die Verlegung auf Sand kann auf zwei Arten erfolgen:

- A) Direkt auf den Sand, nach der Nivellierung der Oberfläche mit einer Nivellierlatte oder einer Holzplatte.
- B) Um einen höhere Stabilität und eine längere Dauer der Verlegung zu haben, einen Untergrund mit einer ca. 15 cm dicken Schicht aus feinem Schotter vorbereiten, diese pressen und nivellieren und dann eine ca. 5 cm dicke Schicht aus Sand auftragen und mit einer Nivellierlatte oder einer Holzplatte nivellieren und dann 20MM trocken verlegen.



20MM

FAVORISCE IL PASSAGGIO E LA MANUTENZIONE DI CABLAGGI E TUBAZIONI.

Facilitates the fixing and the maintenance of wiring and piping systems.

Favorise le passage et l'entretien de câblages et tuyauteries.

Dadurch werden Verlegung und Wartung von Kabeln und Röhren vereinfacht.

FACILITA IL DEFLUSSO DELL'ACQUA.

Facilitates the water draining.

Facilite l'écoulement de l'eau.

Dadurch wird der Wasserablauf vereinfacht.

Per un corretto deflusso dell'acqua si consiglia la posa con una pendenza minima di 1%.

For a proper water outflow we suggest to lay with 1% minimum slope.

Pour un écoulement correct de l'eau il est recommandé de poser avec une pente minimale de 1%.

Um den normalen Wasserabfluss zu gewährleisten, wird eine Verlegung mit mindestens 1% Gefälle empfohlen.



POSA SOPRAELEVATA

RAISED LAYING.
LA POSE SURÉLEVÉE.
DIE VERLEGUNG ALS DOPPELBODEN.

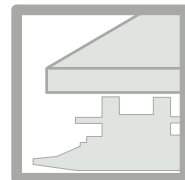

Su terrazze o solai praticabili è possibile realizzare un pavimento sopraelevato piano, che permetta comunque l'evacuazione dell'acqua piovana.

- 1) Dopo la realizzazione del solaio e delle relative pendenze, installare la guaina impermeabilizzante.
- 2) Posizionare i supporti in base al formato scelto utilizzando se necessario i correttori di pendenza.
- 3) Durante la posa regolare ciascun supporto per ottenere un pavimento planare.

On terraces or accessible attics, it is possible to build a raised level flooring that still allows rainwater drainage.

- 1) After the attic and its sloping are complete, install the waterproofing membrane.
- 2) Position the supports in relation to the chosen format, if necessary using slope correctors.
- 3) During regular installation, adjust each pedestal to achieve a flat floor.

Sur des terrasses ou planchers praticables, il est possible de réaliser un sol surélevé plat qui permet dans tous les cas l'écoulement de l'eau de pluie.

- 1) Après la réalisation du plancher et des pentes correspondantes, installer la gaine imperméabilisante.
- 2) Positionner les supports selon le format choisi en utilisant au besoin des correcteurs de pente.
- 3) Au cours de la pose, régler les supports pour obtenir un sol plat.

Auf Terrassen oder begehbaren Dachböden kann man einen flachen Doppelboden realisieren, der den Abfluss des Regenwassers erlaubt.

- 1) Nach der Realisierung des Dachbodens und der entsprechenden Neigungen die Abdichtungsbahn einbauen.
- 2) Die Unterlagen je nach dem gewählten Format positionieren, wenn nötig mit der Verwendung des Neigungsausgleichers.
- 3) Während der Verlegung jede Unterlage regulieren, um einen flachen Boden zu erhalten.

Correttori di pendenza

SLOPE REGULATORS.
CORRECTEURS DE PENTE.
STELZLAGERN MIT NEIGUNGSREGLERN.



Superfici planari.
Plane surfaces.
Gleichen Ebenen Flächen.
Surfaces planes.



Superfici inclinate.
Inclined surfaces.
Flächen mit Neigungswinkel.
Surfaces inclinées.



DELTA Grigio 60x60

SUPPORTI . Supports . Supports . Stelzlager



Supporto 22-30



Supporto 28-37



Supporto 35-50



Supporto 50-70



Supporto 65-100



Supporti di altezza superiore sono disponibili a richiesta.

Higher pedestals are available on request.
Supports de hauteur majeure disponibles sur demande.
Höher verstellbare Stelzlager sind auf Anfrage vorhanden.

CORRETTORI DI PENDENZA . Slope regulators . Neigungsverstellager . Correcteurs de pente



1 %



2 %



3 %



Per pendenze superiori al 3% è possibile sovrapporre più correttori di pendenza.

For slopes over 3%, two or more slope regulators can be piled up on each other.

1% 2% 3% Pour des pentes supérieures à 3% on peut superposer plusieurs correcteurs de pente.

Bei Gefällen ueber 3% darf man mehreren Neigungsregler aufeinander verwenden.

Numero di supporti necessari in funzione del formato della piastrella.

Number of necessary pedestals in proportion to tile format.

Nombre de supports nécessaires en fonction du format de la dalle.
Die Anzahl der notwendigen Unterlagen hängt vom Fliesenformat ab.

Per una corretta posa si consiglia di disporre i supporti come segue:

For a correct installation, we recommend arranging the pedestals as follows:

Pour une pose correcte, il est conseillé de positionner les supports comme suit:
Für eine korrekte Verlegung wird empfohlen, die Unterlagen aufzustellen wie folgt:

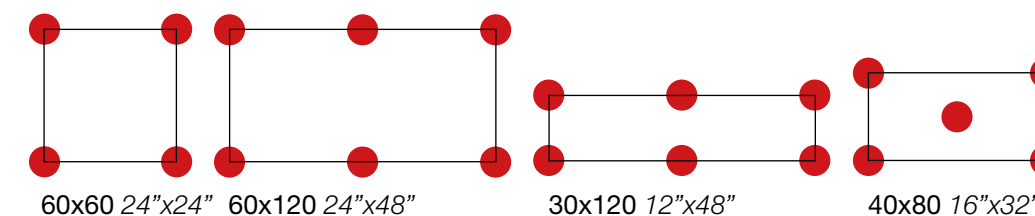

Posa sopraelevata in prossimità di un muro.

Raised installation next to a wall.
Verlegung als Doppelboden nahe bei der Mauer.
Pose surélevée à proximité d'un mur.

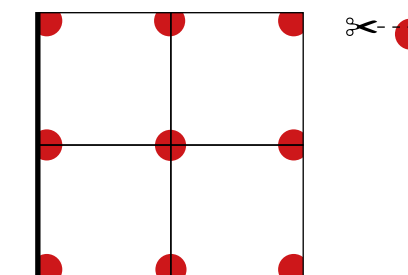

20MM



POSA TRADIZIONALE



**INSTALLATION ON SCREED.
POSE SUR CHAPE.
VERLEGUNG AUF ESTRICH.**

Possibile utilizzare sia la versione con bordi naturali che quella con bordi rettificati per ottenere fughe più sottili.

Possible with both natural and rectified edges for narrower tile gaps.

Il est possible d'utiliser la version avec bords naturels mais aussi celle avec bords rectifiés pour obtenir des joints plus fins.

Es kann sowohl die Version mit natürlichen Rändern als auch die mit rektifizierten Rändern verwendet werden, um schmalere Fugen zu erhalten.



Per applicazioni carrabili o sottoposte a sollecitazioni eccezionali procedere alla posa di 20MM incollandolo su massetto cementizio. Lasciare fuga da 2 mm almeno e rispettare i giunti di dilatazione.

Per realizzare un massetto su terreno:

- realizzare lo scavo e compattare il fondo;
- posizionare uno strato di pietrisco e stabilizzato;
- realizzare il massetto con eventuale rete elettrosaldata;
- procedere alla posa di 20MM con colla cementizia elastica per esterni.

For surfaces that will be used by vehicles or subject to very high stress, install 20MM by bonding it to cement screed. Leave a tile gap of at least 2 mm and respect expansion joints.

To install screed on ground:

- complete the digging and compact the ground;
- place a layer of crushed stone and stabilized gravel;
- make the screed with any electrowelded mesh;
- proceed with laying 20MM with cement glue (elastic) for exteriors.

Pour des applications pour véhicules ou soumises à des sollicitations exceptionnelles, poser 20MM en le collant sur une chape de ciment. Laisser des joints de 2 mm au moins et respecter les joints de dilatation.

Pour réaliser une chape sur terrain :

- creuser une fosse et compacter le fond ;
- poser une couche de cailloutis stabilisée ;
- réaliser la chape avec un éventuel réseau électro-soudé ;
- poser 20MM au moyen d'une colle de ciment (élastique) pour extérieurs.

Für befahrbaren oder außergewöhnlichen Belastungen ausgesetzte Anwendungen die Verlegung von 20MM vornehmen, indem man es auf Zementestrich anklebt. Fugen von mindestens 2 mm lassen und die Dehnungsfugen einhalten.

Realisierung eines Estrichs auf Erdreich:

- die Ausgrabung vornehmen und den Grund verdichten;
- eine Schicht Schotter und Stabilisator positionieren;
- den Estrich mit einem eventuellen elektrogeschweißten Netz realisieren;
- die Verlegung von 20MM mit (elastischem) Zementkleber für den Außenbereich vornehmen.

PEZZI SPECIALI

**SPECIAL PIECES.
FORMTEILE.
PIÈCES SPÉCIALES.**

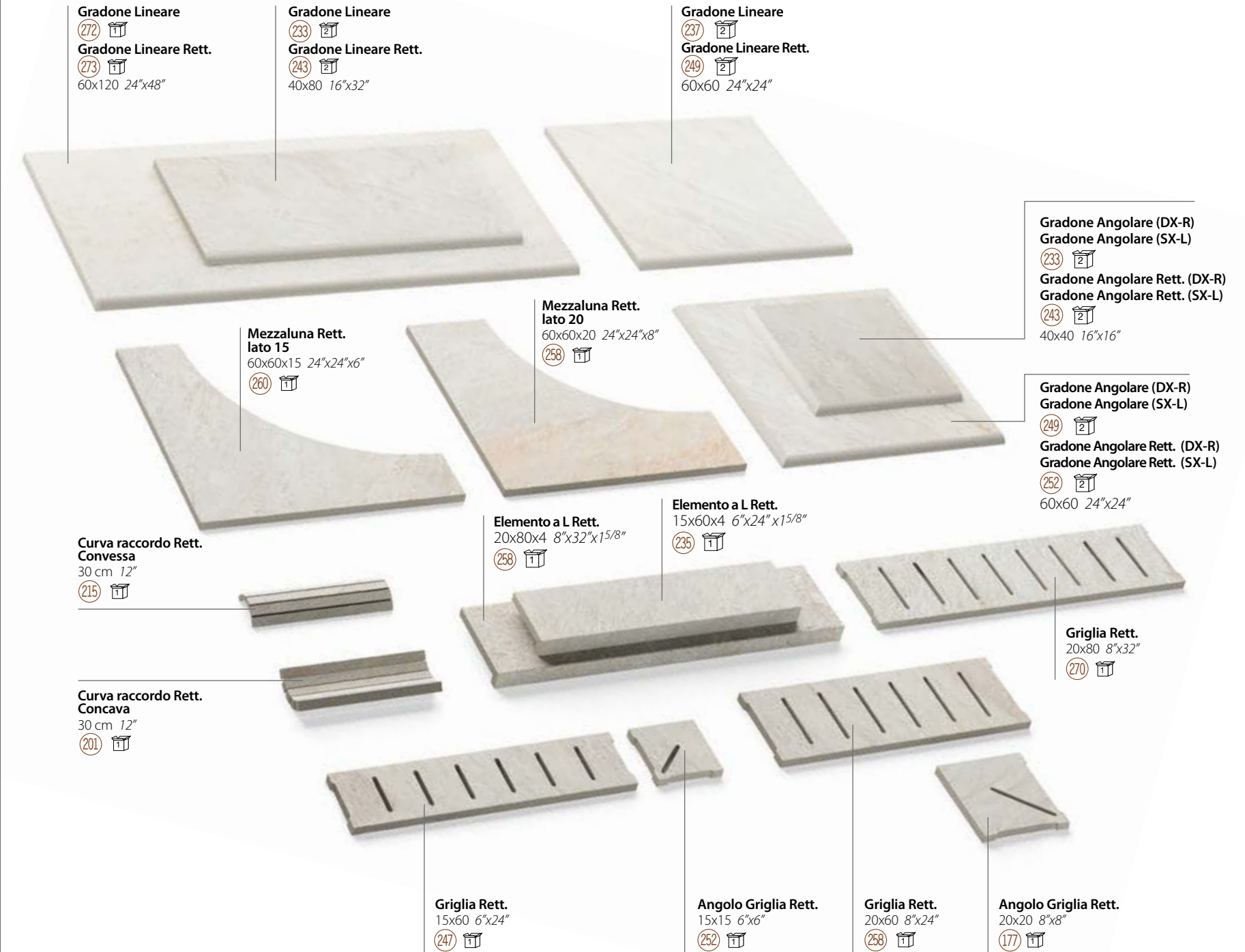

PEZZI SPECIALI PERSONALIZZATI

SPECIAL PERSONALISED PARTS.
PIÈCES SPÉCIALES PERSONNALISÉES.
INDIVIDUELLE GESTALTETE FORMTEILE.

20MM

Su richiesta possono essere realizzati pezzi personalizzati previo studio di fattibilità. Nell'immagine alcuni esempi.

Upon request, personalised pieces can be made, subject to a feasibility study. A few examples in the image.

Sur demande, des pièces personnalisables peuvent être réalisées après une étude de faisabilité. Voici quelques exemples sur l'image.

Auf Anfrage können nach vorheriger Machbarkeitsstudie individuell gestaltete Teile hergestellt werden. Im Bild einige Beispiele.

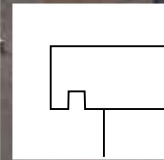
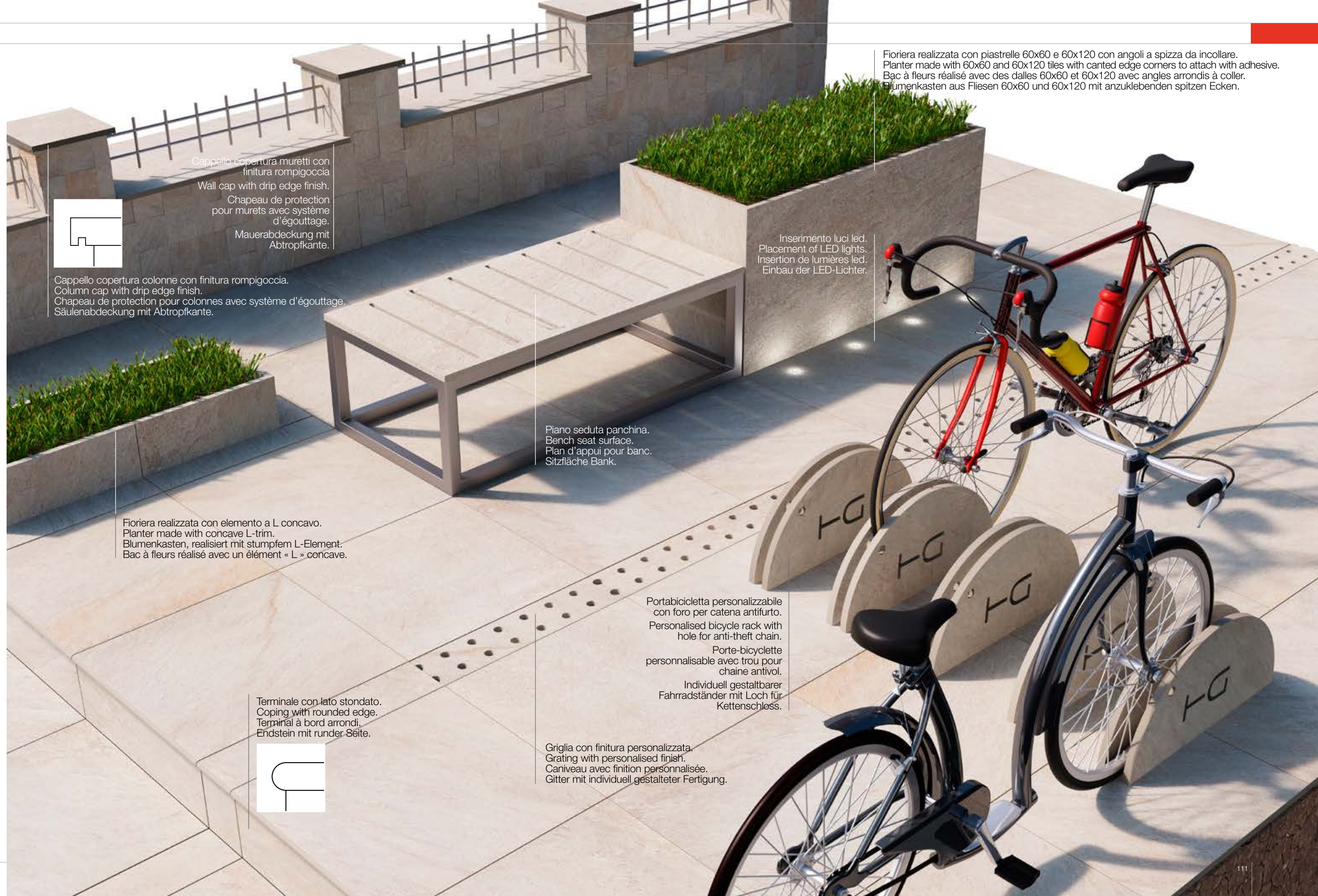

Cappello copertura muretti con finitura rompigoccia.
Wall cap with drip edge finish.
Chapeau de protection pour murets avec système d'égouttage.
Mauerabdeckung mit Abtropfkante.

Cappello copertura colonne con finitura rompigoccia.
Column cap with drip edge finish.
Chapeau de protection pour colonnes avec système d'égouttage.
Säulenabdeckung mit Abtropfkante.

Piano seduta panchina.
Bench seat surface.
Plan d'appui pour banc.
Sitzfläche Bank.

Fioriera realizzata con elemento a L concavo.
Planter made with concave L-trim.
Blumenkasten, realisiert mit stumpfem L-Element.
Bac à fleurs réalisé avec un élément « L » concave.

Terminale con lato stondato.
Coping with rounded edge.
Terminal à bord arrondi.
Endstein mit runder Seite.



Inserimento luci led.
Placement of LED lights.
Insertion de lumières led.
Einbau der LED-Lichter.

Portabicicletta personalizzabile con foro per catena antifurto.
Personalised bicycle rack with hole for anti-theft chain.
Porte-bicyclette personnalisable avec trou pour chaîne antivol.
Individuell gestaltbarer Fahrradständer mit Loch für Kettenschloss.

Griglia con finitura personalizzata.
Grating with personalised finish.
Caniveau avec finition personnalisée.
Gitter mit individuell gestalteter Fertigung.

Fioriera realizzata con piastrelle 60x60 e 60x120 con angoli a spizza da incollare.
Planter made with 60x60 and 60x120 tiles with canted edge corners to attach with adhesive.
Bac à fleurs réalisé avec des dalles 60x60 et 60x120 avec angles arrondis à coller.
Blumenkasten aus Fliesen 60x60 und 60x120 mit anzuklebenden spitzen Ecken.

60x120^{16"x48"} . 30x120^{8"x48"} .

SHADE SPECTRUM

Low <input type="checkbox"/>	Moderate <input checked="" type="checkbox"/>	High <input type="checkbox"/>	Random <input type="checkbox"/>

DIN 51130	DIN 51097	NATURALE	NATURALE
R11	C	ASTM C1028	B.C.R.A.
		dry ≥ 0,60	dry ≥ 0,40
		wet ≥ 0,60	wet ≥ 0,40

FORMATO	SPESSORE	Pz x	Mqx	Kgx		Mqx	Kgx
60x120	20	1	0,72	32,50	26	18,72	845
30x120	20	2	0,72	32,50	16	11,52	520

AT CORDA

AT ANTRACITE

AT BRUNO



60x120 nat. (€ 114,80)
60x120 rett.



30x120 rett.



60x120 nat. (€ 114,80)
60x120 rett.



30x120 rett.



60x120 nat. (€ 114,80)
60x120 rett.



30x120 rett.



Pezzi SPECIALI

Special trims - Pieces especiales - Sonderstücke - Piezas especiales



- Gradone Lineare nat. 2x60x120
- Gradone Lineare rett. 2x60x120

● DISPONIBILE IN TUTTI I COLORI
Available in all colours - Disponible dans toutes les couleurs - In allen Farben erhältlich - Se comercializas en todos los colores

60x60 24"x24"

SHADE SPECTRUM

Low <input type="checkbox"/>	Moderate <input checked="" type="checkbox"/>	High <input type="checkbox"/>	Random <input type="checkbox"/>

DIN 51130	DIN 51097	ASTM C1028	B.C.R.A.
		dry ≥ 0,60 wet ≥ 0,60	dry ≥ 0,40 wet ≥ 0,40

FORMATO	SPESSORE	Pz x	Mqx	Kgx	Mqx	Kgx
60x60	20	2	0,72	31,80	32	23,04
						1040

GRIGIO 20 | **BEIGE 20** | **ANTRACITE 20**



60x60 nat. 60x60 rett.



60x60 nat. 60x60 rett.

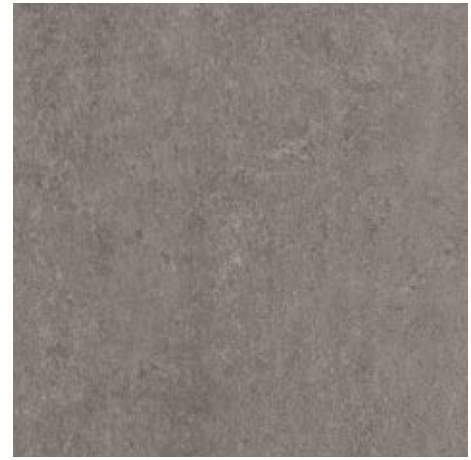

60x60 nat. 60x60 rett.



Pezzi SPECIALI Special trims - Piezas especiales - Sonderstücke - Piezas especiales

	<ul style="list-style-type: none"> Gradone Lineare nat. 60x60 Gradone Lineare rett. 60x60 		<ul style="list-style-type: none"> Gradone Angolare nat. 60x60 Gradone Angolare rett. 60x60
--	---	--	---

● DISPONIBILE IN TUTTI I COLORI
Available in all colours - Disponible dans toutes les couleurs - In allen Farben erhältlich - Se comercializas en todos los colores

60x60^{24"x24"}.

SHADE SPECTRUM

Low Moderate High Random

DIN 51130	DIN 51097	NATURALE ASTM C1028	NATURALE B.C.R.A.
R12	C	dry ≥ 0,60 wet ≥ 0,60	dry ≥ 0,40 wet ≥ 0,40

FORMATO	SPESSORE	Pz x	Mqx	Kgx	x	Mqx	Kgx
60x60	20	2	0,72	31,80	32	23,04	1040,00

- QD20MM FUMÉ
- QD20MM BEIGE
- QD20MM ANTRACITE



60x60 nat.
60x60 rett. 184 184
189 189



60x60 nat.
60x60 rett. 184 184
189 189



60x60 nat.
60x60 rett. 184 184
189 189



Pezzi SPECIALI Special trims - Piezas especiales - Sonderstücke - Piezas especiales

	• Gradone Lineare nat. 60x60 233		• Gradone Angolare nat. 60x60 243
	• Gradone Lineare rett. 60x60 243		• Gradone Angolare rett. 60x60 251

• DISPONIBILE IN TUTTI I COLORI
Available in all colours - Disponible dans toutes les couleurs - In allen Farben erhältlich - Se comercializas en todos los colores

40x80 16"x31,5"

SHADE SPECTRUM			
Low <input type="checkbox"/>	Moderate <input checked="" type="checkbox"/>	High <input type="checkbox"/>	Random <input type="checkbox"/>

DIN 51130	DIN 51097	B.C.R.A.
		dry ≥ 0,90
		wet ≥ 0,90

FORMATO	SPESSORE	Pz x	Mqx	Kgx	Mqx	Kgx
40x80	20	2	0,64	30	24	15,36 / 720

SH GHIACCIO **SH NOTTE** **SH TERRA**



40x80 nat. **20mm**
40x80 rett. **20mm**



40x80 nat. **20mm**
40x80 rett. **20mm**



40x80 nat. **20mm**
40x80 rett. **20mm**



Pezzi SPECIALI Special trims - Piezas especiales - Sonderstücke - Piezas especiales 20MM			
	<ul style="list-style-type: none"> ● Gradone Lineare nat. 2x40x80 ● Gradone Lineare rett. 2x40x80 		<ul style="list-style-type: none"> ● Gradone Angolare nat. 2x40x40 ● Gradone Angolare rett. 2x40x40

● DISPONIBILE IN TUTTI I COLORI
Available in all colours - Disponible dans toutes les couleurs - In allen Farben erhältlich - Se comercializas en todos los colores

OUT: SH Ghiaccio 40x80 rett. 20mm / IN: SH Ghiaccio 80x80 rett.

SHADE SPECTRUM		DIN 51130	DIN 51097	NATURALE ASTM C1028	NATURALE B.C.R.A.
				dry ≥ 0,60	dry ≥ 0,40
Low <input type="checkbox"/>	Moderate <input type="checkbox"/>			wet ≥ 0,60	wet ≥ 0,40

V.360 WHITE V.360 GREY V.360 BLACK

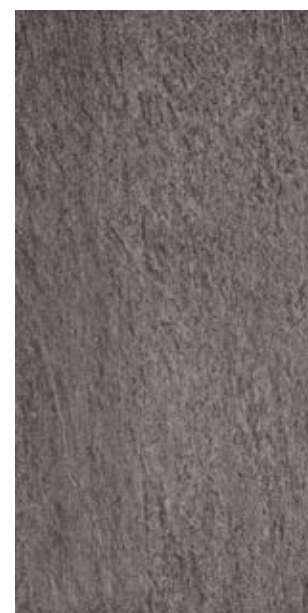

40x80 nat.	40x80 nat.	40x80 nat.
40x80 rett.	40x80 rett.	40x80 rett.

FORMATO	SPESSORE	Pzx	Mqx	Kgx		Mqx	Kgx
40x80	20	2	0,64	30	24	15,36	720

SHADE SPECTRUM		DIN 51130	DIN 51097	D.C.O.F.	B.C.R.A.
				≥ 0,42	dry ≥ 0,40
Low <input type="checkbox"/>	Moderate <input type="checkbox"/>				wet ≥ 0,40

GRIGIO BLU



60x60 nat.	60x60 nat.
60x60 rett.	60x60 rett.

FORMATO	SPESSORE	Pzx	Mqx	Kgx		Mqx	Kgx
60x60	20	2	0,72	31,80	32	23,04	1040



Pezzi SPECIALI
Special trims - Pièces spéciales
Sonderstücke - Piezas especiales

- Gradone Lineare nat. 2x40x80
- Gradone Lineare rett. 2x40x80

- Gradone Angolare nat. 2x40x40
- Gradone Angolare rett. 2x40x40

● DISPONIBILE IN TUTTI I COLORI
Available in all colours.
Disponible dans toutes les couleurs.
In allen Farben erhältlich.
Se comercializas en todos los colores.



Pezzi SPECIALI
Special trims - Pièces spéciales
Sonderstücke - Piezas especiales

- Gradone Lineare nat. 60x60
- Gradone Lineare rett. 60x60

- Gradone Angolare nat. 60x60
- Gradone Angolare rett. 60x60

● DISPONIBILE IN TUTTI I COLORI
Available in all colours.
Disponible dans toutes les couleurs.
In allen Farben erhältlich.
Se comercializas en todos los colores.



MADERA 20MM

40x80 16"x32"

SHADE SPECTRUM		DIN 51130	DIN 51097	D.C.O.F.	B.C.R.A.
				≥ 0,42	dry ≥ 0,40
Low <input type="checkbox"/>	Moderate <input checked="" type="checkbox"/>				wet ≥ 0,40
High <input type="checkbox"/>	Random <input type="checkbox"/>				

MA ROVERE MA PERLA

FORMATO	SPESSORE	Pz x	Mqx	Kgx	Mqx	Kgx
40x80	20	2	0,64	30	24	15,36
						720



40x80 nat. 40x80 rett.

40x80 nat. 40x80 rett.



Pezzi SPECIALI

Special trims - Pieces speciales - Sonderstücke - Piezas especiales

- Gradone Lineare nat. 40x80
- Gradone Lineare rett. 40x80

- Gradone Angolare nat. 40x40
- Gradone Angolare rett. 40x40

● DISPONIBILE IN TUTTI I COLORI
Available in all colours.
Disponible dans toutes les couleurs.
In allen Farben erhältlich.
Se comercializas en todos los colores.

Pezzi SPECIALI

Special trims - Pieces speciales - Sonderstücke - Piezas especiales



Caratteristiche TECNICHE

Technical features - Caractéristiques techniques - Technische Daten - Características Técnicas

	Spessore. Thickness. Épaisseur. Stärke.	Resistenza chimica. Chemical resistance. Résistance chimique. Beständigkeit gegen chemikalien.	Resistenza alla flessione. Bending strenght. Résistance au poinçonnement statique. Biegefestigkeit.	Resistenza al gelo. Frost resistance. Résistance au gel. Frostbeständigkeit.	Assorbimento d'acqua. Water absorption. Absorption d'eau. Wasseraufnahme.	Carico di rottura medio. Breakage load. Charge de rupture. Bruchlast.	Resistenza meccanica. Mechanical strenght. Classe d'appellation. Mechanische festigkeit.
60x60 24"x24"	20 mm	GA UNI EN ISO 10545.13 5 UNI EN ISO 10545.14	~50 N/mm ² EN 14411 Bla	RESISTANT ISO 10545.12	~0,1 % ISO 10545.3	Classe 1 (~ 7,00 kN al centro) EN 12825	U11 EN 1339
40x80 16"x32"	20 mm	GA UNI EN ISO 10545.13 5 UNI EN ISO 10545.14	~50 N/mm ² EN 14411 Bla	RESISTANT ISO 10545.12	~0,1 % ISO 10545.3	Classe 1 EN 12825	
60x120 24"x48"	20 mm	GA UNI EN ISO 10545.13 5 UNI EN ISO 10545.14	~50 N/mm ² EN 14411 Bla	RESISTANT ISO 10545.12	~0,1 % ISO 10545.3	Classe 1 EN 12825	
30x120 12"x48"	20 mm	GA UNI EN ISO 10545.13 5 UNI EN ISO 10545.14	~50 N/mm ² EN 14411 Bla	RESISTANT ISO 10545.12	~0,1 % ISO 10545.3	Classe 1 EN 12825	

GRES PORCELLANATO SMALTATO

FULL DEPTH VITRIFIED STONEWARE - GRÈS CERAME À TOUTE ÉPAISSEUR - FEINSTEINZEUG AUF GANZER DICKE - GRES PORCELÁNICO A TODO ESPESOR

**Residenziale, bagni, cucine, interni, esterni, scale, davanzali.
Showrooms commerciali, alberghi, negozi, uffici, ristoranti.**



Housing, bathrooms,
kitchens, interiors,
exteriors, stairs,
window ledges.

Zones résidentielles,
salles de bains,
cuisines, escaliers,
rebords.

Wohnräume, Bäder,
Küchen,
Innen- und Außenräume,
Treppen, Simse.

Chalets, cuartos de baño,
cocinas, interiores,
exteriores, escaleras,
alféizares.

Sales showrooms, hotels,
shops,
offices, restaurants.

Showrooms commerciaux, hôtels,
magasins,
bureaux, restaurants.

Verkauf-Schauräume, Hotels,
Geschäfte,
Büros, Restaurants.

Salas de exposición comerciales,
hoteles, tiendas,
oficinas, restaurantes.

RESISTENZA all'ABRASIONE

*Abrasion Resistance
Résistance À L'abrasion
Abriebfestkeit
Resistencia A La Abrasión*

RESISTENZA al GELO

*Frost Resistance
Résistance Au Gel
Frostbeständigkeit
Resistencia Al Hielol*

RESISTENZA ai CARICHI di ROTTURA

*Breaking Load Resistance
Résistance Aux Charges De Rupture
Bruchlastbeständigkeit
Resistencia A Las Cargas De Ruptura*

RESISTENZA agli ACIDI

*Acid Resistance
Résistance Aux Acides
Säurefestkeit
Resistencia A Los Ácidos*

RESISTENZA agli URTI

*Impact Strength
Résistance Aux Chocs
Schlagfestkeit
Resistencia A Los Golpes*

RESISTENZA alle MACCHIE

*Stain Resistance
Résistance Aux Taches
Fleckenbeständigkeit
Resistencia A Las Manchas*



AMALFI

45x45 18"x18"

SHADE SPECTRUM

Low Moderate High Random

B.C.R.A.

dry ≥ 0,40

wet ≥ 0,40

FORMATO	SPESSORE	Pzx	Mqx	Kgx	Mqx	Kgx
45x45	9,5	5	1,01	24	34	34,34

BIANCO

BEIGE



45x45 53 53



45x45 53 53



Amalfi Fascia Bianco 7,5x45 119 6



Amalfi Fascia Beige 7,5x45 119 6



Amalfi Tozzetto 7,5x7,5 57 1 set x



Amalfi Tozzetto 7,5x7,5 57 1 set x

Pezzi SPECIALI

Special trims - Pieces especiales - Sonderstücke - Piezas especiales

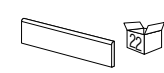

Battiscopa. 9x45 12

DISPONIBILE IN TUTTI I COLORI
Available in all colours - Disponible dans toutes les couleurs - In allen Farben erhältlich - Se comercializas en todos los colores



Beige 45x45 . Amalfi tozzetto



ANTICHE DOGHE

15x60⁶x24".

SHADE SPECTRUM			
Low <input type="checkbox"/>	Moderate <input type="checkbox"/>	High <input type="checkbox"/>	Random <input type="checkbox"/>

DIN 51130	DIN 51097	ASTM C1028	B.C.R.A.
		dry ≥ 0,60 wet ≥ 0,60	dry ≥ 0,40 wet ≥ 0,40

FORMATO	SPESSORE	Pzx	Mqx	Kgx	Mqx	Kgx
15x60	10,3	12	1,08	24	44	47,52
						1076

A.D MIELE	A.D BIANCO	A.D NOCE	A.D GRIGIO	A.D CAFFÈ
15x60 	15x60 	15x60 	15x60 	15x60
Mosaico 30x30 (2,5x15) 	Mosaico 30x30 (2,5x15) 	Mosaico 30x30 (2,5x15) 	Mosaico 30x30 (2,5x15) 	Mosaico 30x30 (2,5x15)
A.D Miele Decoro 15x60 	A.D Bianco Decoro 15x60 	A.D Noce Decoro 15x60 	A.D Grigio Decoro 15x60 	A.D Caffè Decoro 15x60



AD Grigio 15x60 nat.

Pezzi SPECIALI

Special trims - Pieces especiales - Sonderstücke - Piezas especiales

- Battiscopa 7,5x60
- Gradone assemblato 15x60x3

● DISPONIBILE IN TUTTI I COLORI
Available in all colours - Disponible dans toutes les couleurs - In allen Farben erhältlich - Se comercializas en todos los colores



ANTICHE DOGHE

15x60⁶x24".



AD Miele 15x60 nat.



AD Noce 15x60 nat.



AD Caffè 15x60 nat.



AD Bianco 15x60 nat.



COUNTRY LIFE

20x80 8"x31,5".

SHADE SPECTRUM			
Low <input type="checkbox"/>	Moderate <input type="checkbox"/>	High <input type="checkbox"/>	Random <input type="checkbox"/>

DIN 51130	DIN 51097	ASTM C1028	B.C.R.A.
		dry ≥ 0,60 wet ≥ 0,60	dry ≥ 0,40 wet ≥ 0,40

FORMATO	SPESSORE	Pz x	Mqx	Kgx	Mqx	Kgx
20x80	10,3	7	1,12	25,08	42	1053,36

CL MIELE	CL BIANCO	CL TORTORA	CL NOCE
----------	-----------	------------	---------



20x80 nat.



20x80 nat.



20x80 nat.



20x80 nat.

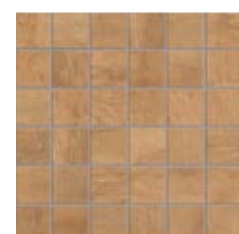

CL Miele Mosaico 30x30 (5x5)



CL Bianco Mosaico 30x30 (5x5)



CL Tortora Mosaico 30x30 (5x5)

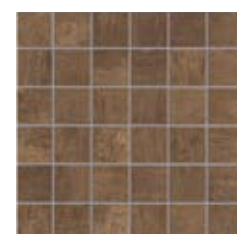

CL Noce Mosaico 30x30 (5x5)



CL Miele Muretto 20x80 nat.



CL Tortora Muretto 20x80 nat.



CL Bianco Muretto 20x80 nat.

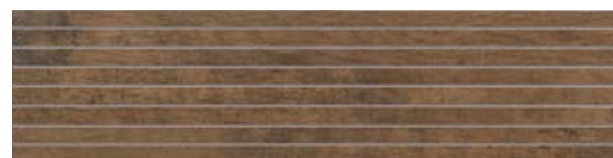

CL Noce Muretto 20x80 nat.



CL Rosone Country 80x80 € 253,00



CL Rosone Life 80x80 € 253,00



CL Bianco Fascia 20x80 nat.



CL Tortora Fascia 20x80 nat.



CL Miele Fascia 20x80 nat.



CL Noce Fascia 20x80 nat.

Pezzi SPECIALI

Special trims - Pieces especiales - Sonderstücke - Piezas especiales

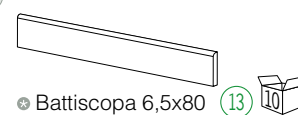

● Battiscopa 6,5x80

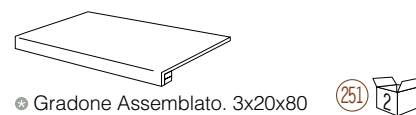

● Gradone Assemblato. 3x20x80

● DISPONIBILE IN TUTTI I COLORI
Available in all colours - Disponible dans toutes les couleurs - In allen Farben erhältlich - Se comercializas en todos los colores



20x80 8"x31,5".



CLNoce 20x80 nat.



CLBianco 20x80 nat.
CLBianco Fascia 20x80 nat.



CLTortora 20x80 nat.
CLRosone Life 80x80



CLMiele 20x80 nat.
CLMiele Muretto 20x80 nat.

**ELITE**80x80^{32"x32"}. 40x80^{16"x32"}. 60x60^{24"x24"}. 30x60^{12"x24"}.**CARRARA**

SHADE SPECTRUM			
Low <input type="checkbox"/>	Moderate <input checked="" type="checkbox"/>	High <input type="checkbox"/>	Random <input type="checkbox"/>

NATURALE	NATURALE	NATURALE	NATURALE
DIN 51130	DIN 51097	ASTM C1028	B.C.R.A.
R9	A	dry ≥ 0,60 wet ≥ 0,60	dry ≥ 0,40 wet ≥ 0,40

FORMATO	SPESSORE	Pzx	Mqx	Kgx	Mqx	Kgx
80x80	10,3	2	1,28	29,40	40	51,20
40x80	10,3	3	0,96	22,00	28	26,88
60x60	10,3	4	1,44	32,50	30	43,20
30x60	10,3	6	1,08	23,50	40	43,20

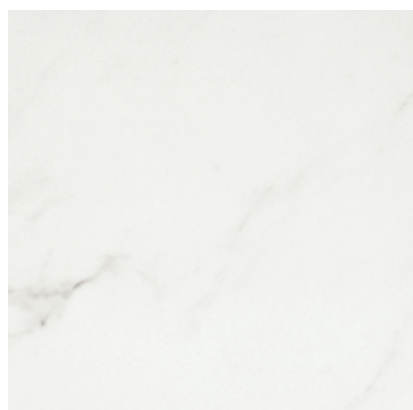
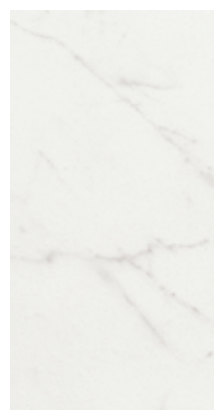
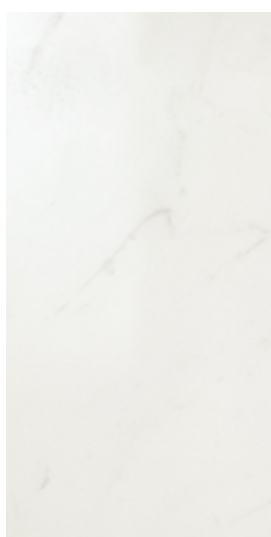
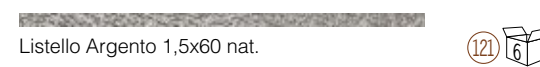
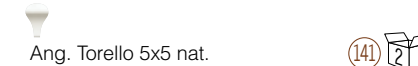
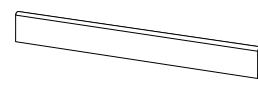
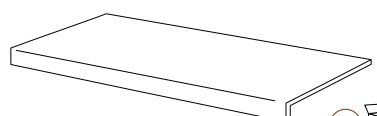
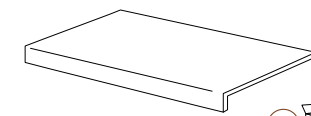
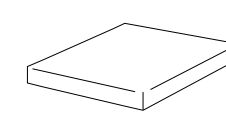
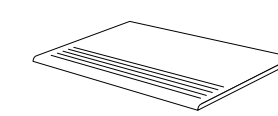
80x80 nat./rett.
177 **177**40x80 nat./rett.
155 **155**60x60 nat.
109 **109**30x60 nat.
87 **87**80x80 lapp./rett.
184 **184**40x80 lapp./rett.
175 **175**60x60 lapp./rett.
175 **175**30x60 lapp./rett.
161 **161****Decori** Special trims - Sonderstücke - Pieces especiales - Piezas especialesElite 40x80 lapp./rett. **190** **190** **3**Dec. 30x60 nat.
Dec. 30x60 lapp./rett. **143** **143** **6**
177 **177** **6**Mosaico (5x5)
30x30 nat. **195** **195** **5**Elite 7,5x80 lapp./rett. **137** **4**Listello 7,5x60 lapp./rett. **53** **6**Mosaico 3D (7,5x7,5)
30x30 lapp./rett. **173** **5**Listello 7,5x80 lapp./rett. **90** **6**Tozzetto 7x7 lapp./rett. **9** **4**Matita 1,6x60 nat. **95** **4**Ang. Matita 1,6x1,6 **153** **2**Listello Argento 1,5x60 nat. **121** **6**Torello 5x30 nat. **125** **6**Listello Bronzo 1,5x60 nat. **121** **6**Ang. Torello 5x5 nat. **141** **2**Esagona 10
30x30 nat./rett. **202** **202** **5****Pezzi SPECIALI** Special trims - Pieces especiales - Sonderstücke - Piezas especialesBattiscopa 7,5x80 nat./rett. **13** **10**Battiscopa 7,5x60 nat. **12** **12**Gradone 3x33x80 nat. **257** **2**Gradone 3x33x60 nat. **233** **4**Ang Gradone 33x33 nat. **227** **2**Step 30x60 nat. **141** **6**

**ELITE**80x80_{32"x32"}. 40x80_{16"x32"}. 60x60_{24"x24"}. 30x60_{12"x24"}.**PULPIS**

SHADE SPECTRUM			
Low <input type="checkbox"/>	Moderate <input checked="" type="checkbox"/>	High <input type="checkbox"/>	Random <input type="checkbox"/>

NATURALE	NATURALE	NATURALE	NATURALE
DIN 51130	DIN 51097	ASTM C1028	B.C.R.A.
		dry ≥ 0,60 wet ≥ 0,60	dry ≥ 0,40 wet ≥ 0,40

FORMATO	SPESSORE	Pz x	Mqx	Kgx		Mqx	Kgx
80x80	10,3	2	1,28	29,40	40	51,20	1176
40x80	10,3	3	0,96	22,00	28	26,88	618
60x60	10,3	4	1,44	32,50	30	43,20	975
30x60	10,3	6	1,08	23,50	40	43,20	940

80x80 nat./rett.
40x80 nat./rett.
60x60 nat.
30x60 nat.
80x80 lapp./rett.
40x80 lapp./rett.
60x60 lapp./rett.
30x60 lapp./rett.
Decori Special trims - Sonderstücke - Pieces speciales - Piezas especiales

Elite 40x80 lapp./rett.

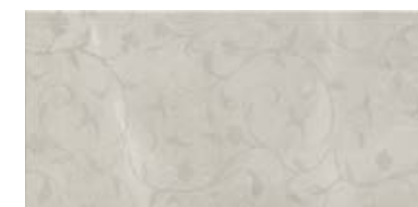
Dec. 30x60 nat.
Dec. 30x60 lapp./rett. Mosaico (5x5)
30x30 nat. 

Elite 7,5x80 lapp./rett.



Listello 7,5x60 lapp./rett.

Mosaico 3D (7,5x7,5)
30x30 lapp./rett. 

Listello 7,5x80 lapp./rett.



Tozzetto 7x7 lapp./rett.



Matita 1,6x60 nat.



Ang. Matita 1,6x1,6

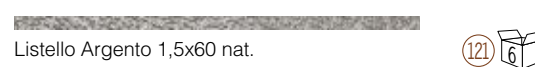

Listello Argento 1,5x60 nat.

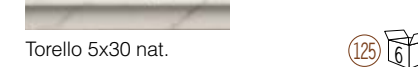

Torello 5x30 nat.



Listello Bronzo 1,5x60 nat.

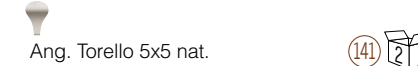

Ang. Torello 5x5 nat.

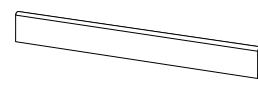
Esagona 10
30x30 nat./rett. **Pezzi SPECIALI** Special trims - Pieces speciales - Sonderstücke - Piezas especiales

Battiscopa 7,5x80 nat./rett.



Battiscopa 7,5x60 nat.

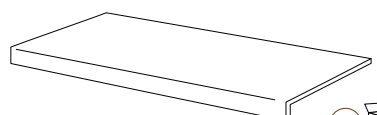

Gradone 3x33x80 nat.

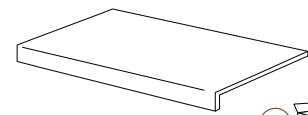

Gradone 3x33x60 nat.

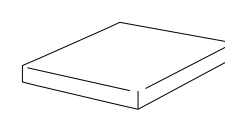

Ang Gradone 33x33 nat.

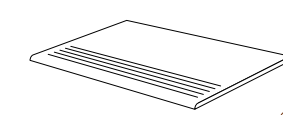

Step 30x60 nat.

**ELITE**80x80^{32"x32"}. 40x80^{16"x32"}. 60x60^{24"x24"}. 30x60^{12"x24"}.**SEGESTA**

SHADE SPECTRUM			
Low <input type="checkbox"/>	Moderate <input checked="" type="checkbox"/>	High <input type="checkbox"/>	Random <input type="checkbox"/>

NATURALE	NATURALE	NATURALE	NATURALE
DIN 51130	DIN 51097	ASTM C1028	B.C.R.A.
R9	A	dry ≥ 0,60 wet ≥ 0,60	dry ≥ 0,40 wet ≥ 0,40

FORMATO	SPESSORE	Pz x	Mqx	Kgx		Mqx	Kgx
80x80	10,3	2	1,28	29,40	40	51,20	1176
40x80	10,3	3	0,96	22,00	28	26,88	618
60x60	10,3	4	1,44	32,50	30	43,20	975
30x60	10,3	6	1,08	23,50	40	43,20	940

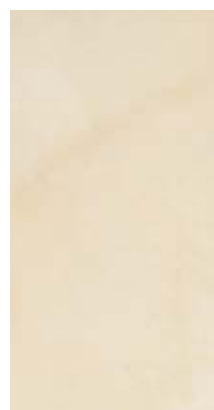
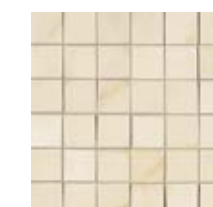
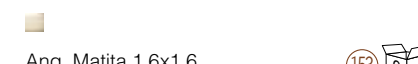
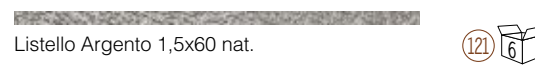
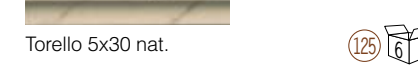
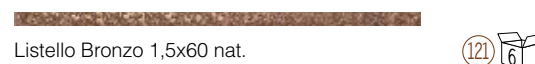
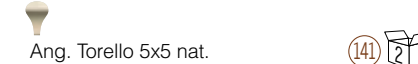
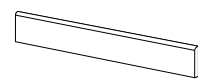
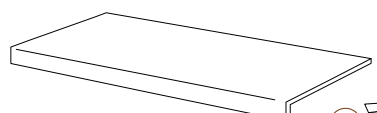
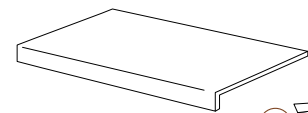
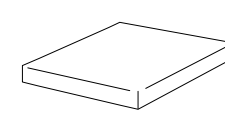
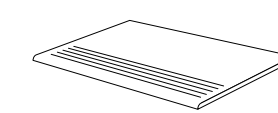
80x80 nat./rett.
177 **177**40x80 nat./rett.
155 **155**60x60 nat.
109 **109**30x60 nat.
87 **87**80x80 lapp./rett.
184 **184**40x80 lapp./rett.
175 **175**60x60 lapp./rett.
175 **175**30x60 lapp./rett.
161 **161****Decori** Special trims - Sonderstücke - Pieces speciales - Piezas especialesElite 40x80 lapp./rett. **190** **190** Dec. 30x60 nat. **143** **143**
Dec. 30x60 lapp./rett. **177** **177** Mosaico (5x5)
30x30 nat. **195** **195** Elite 7,5x80 lapp./rett. **137** Listello 7,5x60 lapp./rett. **53** Mosaico 3D (7,5x7,5)
30x30 lapp./rett. **173** Listello 7,5x80 lapp./rett. **90** Tozzetto 7x7 lapp./rett. **9** Matita 1,6x60 nat. **95** Ang. Matita 1,6x1,6 **153** Listello Argento 1,5x60 nat. **121** Torello 5x30 nat. **125** Listello Bronzo 1,5x60 nat. **121** Ang. Torello 5x5 nat. **141** Esagona 10
30x30 nat./rett. **202** **202** **Pezzi SPECIALI** Special trims - Pieces speciales - Sonderstücke - Piezas especialesBattiscopa 7,5x80 nat./rett. **13** Battiscopa 7,5x60 nat. **12** Gradone 3x33x80 nat. **257** Gradone 3x33x60 nat. **233** Ang Gradone 33x33 nat. **227** Step 30x60 nat. **141**

80x80^{32"x32"}. 40x80^{16"x32"}. 60x60^{24"x24"}. 30x60^{12"x24"}.



80x80_{32"x32"}. 40x80_{16"x32"}. 60x60_{24"x24"}. 30x60_{12"x24"}.



pav: Carrara 40x80 nat./rett. - Pulpis Esagona10 30x30 nat./rett.
riv: Pulpis 40x80 lapp./rett. - Elite 40x80 lapp./rett.



pav: Pulpis Esagona10 30x30 nat./rett.
riv: Pulpis 40x80 lapp./rett. - Elite 40x80 lapp./rett.

80x80_{32"x32"}. 40x80_{16"x32"}. 60x60_{24"x24"}. 30x60_{12"x24"}.



pav: Segesta 60x60 nat.
riv: Segesta Mosaico3D 30x30 lapp./rett.



pav: Segesta 30x60 nat.
riv: Segesta 30x60 lapp./rett. - Listello Bronzo 1,5x60 nat.



20x80 8"x31,5".

SHADE SPECTRUM			
Low <input type="checkbox"/>	Moderate <input type="checkbox"/>	High <input type="checkbox"/>	Random <input type="checkbox"/>

DIN 51130	DIN 51097	ASTM C1028	B.C.R.A.	D.C.O.F.
		dry ≥ 0,60 wet ≥ 0,60	dry ≥ 0,40 wet ≥ 0,40	wet ≥ 0,42

FORMATO	SPESSORE	Pzx	Mqx	Kgx	Mqx	Kgx
20x80	10,3	7	1,12	25,08	42	1053,36

MA BIANCO	MA CENERE	MA ROVERE	MA PERLA
-----------	-----------	-----------	----------



20x80 nat.	MA decoro 20x80 nat.	20x80 nat.	MA decoro 20x80 nat.	20x80 nat.	MA decoro 20x80 nat.	20x80 nat.	MA decoro 20x80 nat.
------------	----------------------	------------	----------------------	------------	----------------------	------------	----------------------



MA Bianco Mosaico 20x20	MA Cenere Mosaico 20x20	MA Rovere Mosaico 20x20	MA Perla Mosaico 20x20
-------------------------	-------------------------	-------------------------	------------------------



MA Bianco Muretto 20x40	MA Cenere Muretto 20x40	MA Rovere Muretto 20x40	MA Perla Muretto 20x40
-------------------------	-------------------------	-------------------------	------------------------



MA MIX Mosaico 20x20	MA MIX Muretto 20x40
----------------------	----------------------



MA BLENDED 20x80 naturale

Blended

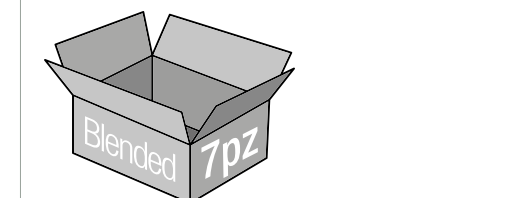

MA Blended 20x80 nat (7 pezzi)

2 pz. MA Perla 20x80 nat
2 pz. MA Rovere 20x80 nat
2 pz. MA Cenere 20x80 nat
1 pz. MA Bianco 20x80 nat

Pezzi SPECIALI

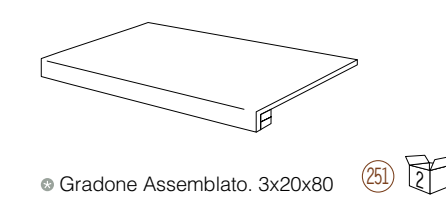
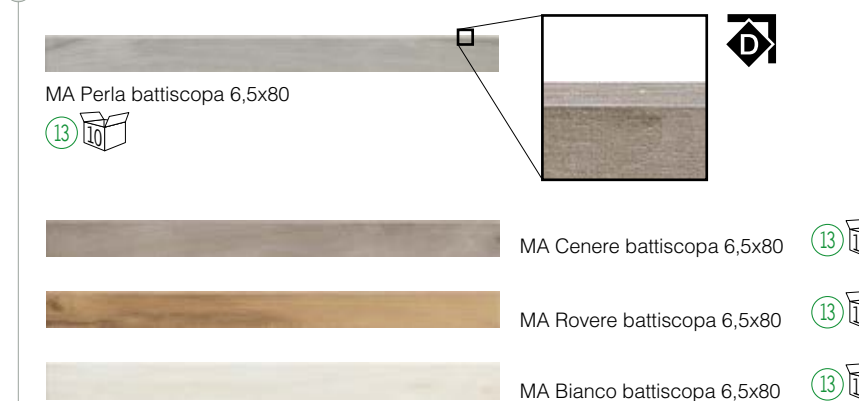

Gradone Assemblato. 3x20x80

● DISPONIBILE IN TUTTI I COLORI
Available in all colours.
Disponibile dans toutes les couleurs.
In allen Farben erhältlich.
Se comercializas en todos los colores.



MABIANCO
20x80 naturale



MACENERE
20x80 naturale



MABIANCO
20x80 naturale



MACENERE
20x80 naturale



MARMI ANTICHI

45x45^{18"x18"}.30x30^{12"x12"}.15x15^{6"x6"}.10x10^{4"x4"} Modular System

SHADE SPECTRUM			
Low <input type="checkbox"/>	Moderate <input type="checkbox"/>	High <input type="checkbox"/>	Random <input type="checkbox"/>

ASTM C1028
dry ≥ 0,60
wet ≥ 0,60

FORMATO	SPESSORE	Pz x	Mqx	Kgx		Mqx	Kgx
45x45	9,5	5	1,01	21,50	34	34,34	731
30x30	10	13	1,17	25,00	40	46,80	1000
15x15	9	48	1,08	24,50	60	64,80	1470
10x10	10	80	0,80	16,40	60	48,00	984
Modular	10	15	1,01	21,50	34	34,34	731

REALE	ANTICO	CLASSICO	ALABASTRO
-------	--------	----------	-----------

45x45 64 64

15x15 37 37

10x10 111 111

45x45 64 64

15x15 37 37

10x10 111 111

45x45 64 64

15x15 37 37

10x10 111 111

45x45 64 64

15x15 37 37

10x10 111 111

30x30 31 31

Mosaico 5x5 (30x30) 230 230

30x30 31 31

Mosaico 5x5 (30x30) 230 230

30x30 31 31

Mosaico 5x5 (30x30) 230 230

30x30 31 31

Mosaico 5x5 (30x30) 230 230

Reale Tozz. 6,5x6,5 39

Reale Fascia 6,5x30 87

Antico Tozz. 6,5x6,5 39

Antico Fascia 6,5x30 87

Classico Tozz. 6,5x6,5 39

Classico Fascia 6,5x30 87

Alabastro Tozz. 6,5x6,5 39

Alabastro Fascia 6,5x30 87

Reale Inserto 15x15 81

Reale Listello 4,5x15 51

Antico Inserto 15x15 81

Antico Listello 4,5x15 51

Classico Inserto 15x15 81

Classico Listello 4,5x15 51

Alabastro Inserto 15x15 81

Alabastro Listello 4,5x15 51

Bacco Formella Set. 3Pz. - 2 sets x 10x10 213

Reale Torello 4,5x10 67

Reale Ang. Torello 123

Maya Decoro Set. 3Pz. - 2 sets x 10x10 213

Maya Listello 5x20 101

Antico Torello 4,5x10 67

Antico Ang. Torello 123

Venere Formella Set. 3Pz. - 2 sets x 10x10 213

Classico Torello 4,5x10 67

Classico Ang. Torello 123

Incas Decoro Set. 3Pz. - 2 sets x 10x10 213

Incas Listello 5x20 101

Alabastro Torello 4,5x10 67

Alabastro Ang. Torello 123

Pezzi SPECIALI

Special trims - Pieces especiales - Sonderstücke - Piezas especiales

Gradino. 30x30 NAT. 73	Battiscopa. 7,2x30 NAT. 9	V-cap. 5,5x15 43	V-cap. ang. h. 5,5 93	QR outside. 3x15 37	Beak outside 89	SBN 15 29	DBN 15 37

● DISPONIBILE IN TUTTI I COLORI
Available in all colours - Disponible dans toutes les couleurs - In allen Farben erhältlich - Se comercializas en todos los colores

Modular SYSTEM

3 Pz. 45x45
2 Pz. 30x30
10 Pz. 15x15

BREVETTATO

SPECIALE CONFEZIONE MODULARE A 15 PEZZI!
Special Modular packaging 15 pcs.
Emballage special 15 pcs.
Sonder Verpackung 15 stück.
Embalaje especial modular con 15 piezas.

Pag. 204

MARMI ANTICHI

45x45^{18"x18"}.30x30^{12"x12"}.15x15^{6"x6"}.10x10^{4"x4"} Modular System



Reale 45x45 . mosaico . Classico 45x45



MARMI ANTICHI

45x45^{18"x18"}.30x30^{12"x12"}.15x15^{6"x6"}.10x10^{4"x4"} Modular System



Alabastro 30x30
Alabastro 15x15 . Alabastro inserto . vcap



Classico 30x30 . Classico fascia . Alabastro 30x30



Reale 10x10 . Reale torelio . Incas decoro . Incas listello



PATINA

30x120^{12"x48"}.20x80^{8"x31,5"}.

SHADE SPECTRUM

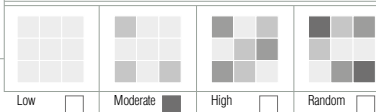

FORMATO	SPESSORE	Pz x	Mqx	Kgx	x	Mqx	Kgx
30x120	10,3	3	1,08	25,00	30	32,40	750,00
20x80	10,3	7	1,12	25,08	42	47,04	1053,36

PA GRIGIO

PA BEIGE

PA CASTANO



30x120 nat.

149 149



20x80 nat.

101 101

20x80 grip

117 117



decoro 20x80 nat.

161 161



muretto 20x80 nat.

187 187



30x120 nat.

149 149



20x80 nat.

101 101

20x80 grip

117 117



decoro 20x80 nat.

161 161



muretto 20x80 nat.

187 187



30x120 nat.

149 149



20x80 nat.

101 101

20x80 grip

117 117



decoro 20x80 nat.

161 161



muretto 20x80 nat.

187 187

Pezzi SPECIALI

Special trims - Peces especiales - Sonderstücke - Piezas especiales

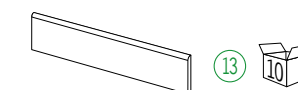

* Battiscopa 6,5x80



* Gradone Assemblato. 3x20x120 nat.

* DISPONIBILE IN TUTTI I COLORI
Available in all colours - Disponible dans toutes les couleurs
In allen Farben erhältlich - Se comercializas en todos los colores



out: PA Grigio 20x80 grip - in: PA Grigio 20x80 nat. - PA Grigio 30x120 nat.



PA Castano 20x80 nat. - PA Beige 20x80 nat. - PA Beige decoro 20x80 nat.



PATINA

30x120^{12"x48"}.20x80^{8"x31,5"}.





TERRE SENESI

30x30^{12"x12"}. 15x30^{6"x12"}

SHADE SPECTRUM

Low Moderate High Random

DIN 51130



FORMATO	SPESSORE	Pzx	Mqx	Kgx	Mqx	Kgx
30x30	8,5	15	1,35	23,60	40	54,00
15x30	8,5	26	1,20	21,80	60	72,00
						944
						1308

CETONA



PEI IV 30x30 (26) (26)



6x6



MONTALCINO



PEI IV 30x30 (26) (26)



PEI IV 15x30 (37) (37)



6x6



Piensa Fascia 6x30



Piensa Tozz. 6x6



Piensa Fascia 6x30



Piensa Tozz. 6x6



Pezzi SPECIALI

Special trims - Píeces especiales - Sonderstücke - Piezas especiales

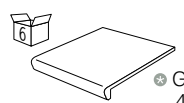

Gradone pressato 4x33x30 (173)

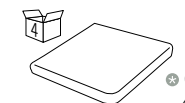

Gradone Ang. pressato 4x33x33 (203)

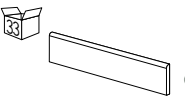

Battiscopa 8x30 (9)

DISPONIBILE IN TUTTI I COLORI
Available in all colours - Disponible dans toutes les couleurs - In allen Farben erhältlich - Se comercializas en todos los colores



Montalcino 30x30 . 15x30 .Piensa fascia



WALNUT

30x120 12"x48"

SHADE SPECTRUM

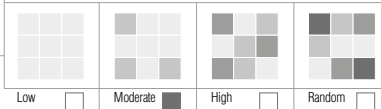

FORMATO	SPESSORE	Pzx	Mqx	Kgx	Mqx	Kgx
30x120	10,3	3	1,08	25,00	30	32,40
						750

120 BEIGE



30x120 nat.

149 149

30x120 ret.

159 159

120 GRIGIO



30x120 nat.

149 149

30x120 ret.

159 159

120 NOCE



30x120 nat.

149 149

30x120 ret.

159 159

Pezzi SPECIALI

Special trims - Pieces especiales - Sonderstücke - Piezas especiales

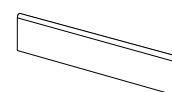

• Battiscopa 6,5x120

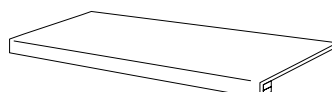

• Gradone Assemblato. 3x20x120 nat.

• Gradone Assemblato. 3x20x120 ret.



• DISPONIBILE IN TUTTI I COLORI

Available in all colours - Disponible dans toutes les couleurs
In allen Farben erhältlich - Se comercializas en todos los colores



120 Grigio 30x120 nat.



WALNUT

30x120^{12"x48"}



120 Beige 30x120 nat. - 120 Noce 30x120 nat.



120 Beige 30x120 ret.



 pastorelli

FORMATO	SPESSORE	Pz x	Mqx	Kgx	Pz x	Mqx	Kgx
20x20	10	27	1,08	19,10	60	64,80	1056

TREVI



Colorforte Formella*

10x20

* 2 soggetti assortiti



20x20



Manarola Decoro
20x20



Atrani Decoro
20x20

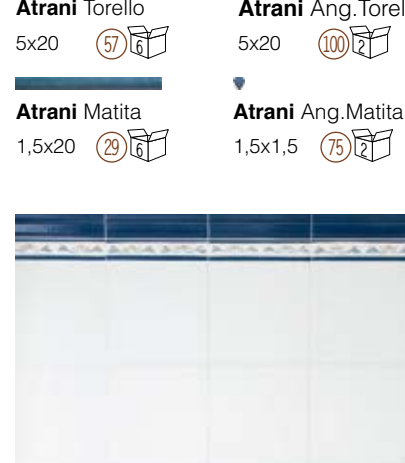

Atrani Listello
4x20



Atrani Ang. Torello
5x20



Atrani Matita
1,5x20



Atrani Ang. Matita
1,5x1,5



Cefalù Formella*

10x20



Trevi Torello
5x20

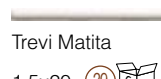

Trevi Matita
1,5x20

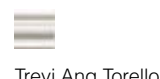

Trevi Ang. Torello
5x5

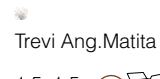

Trevi Ang. Matita
1,5x1,5



Navelli Decoro
20x20



Trevi 20x20
Manarola decoro 20x20

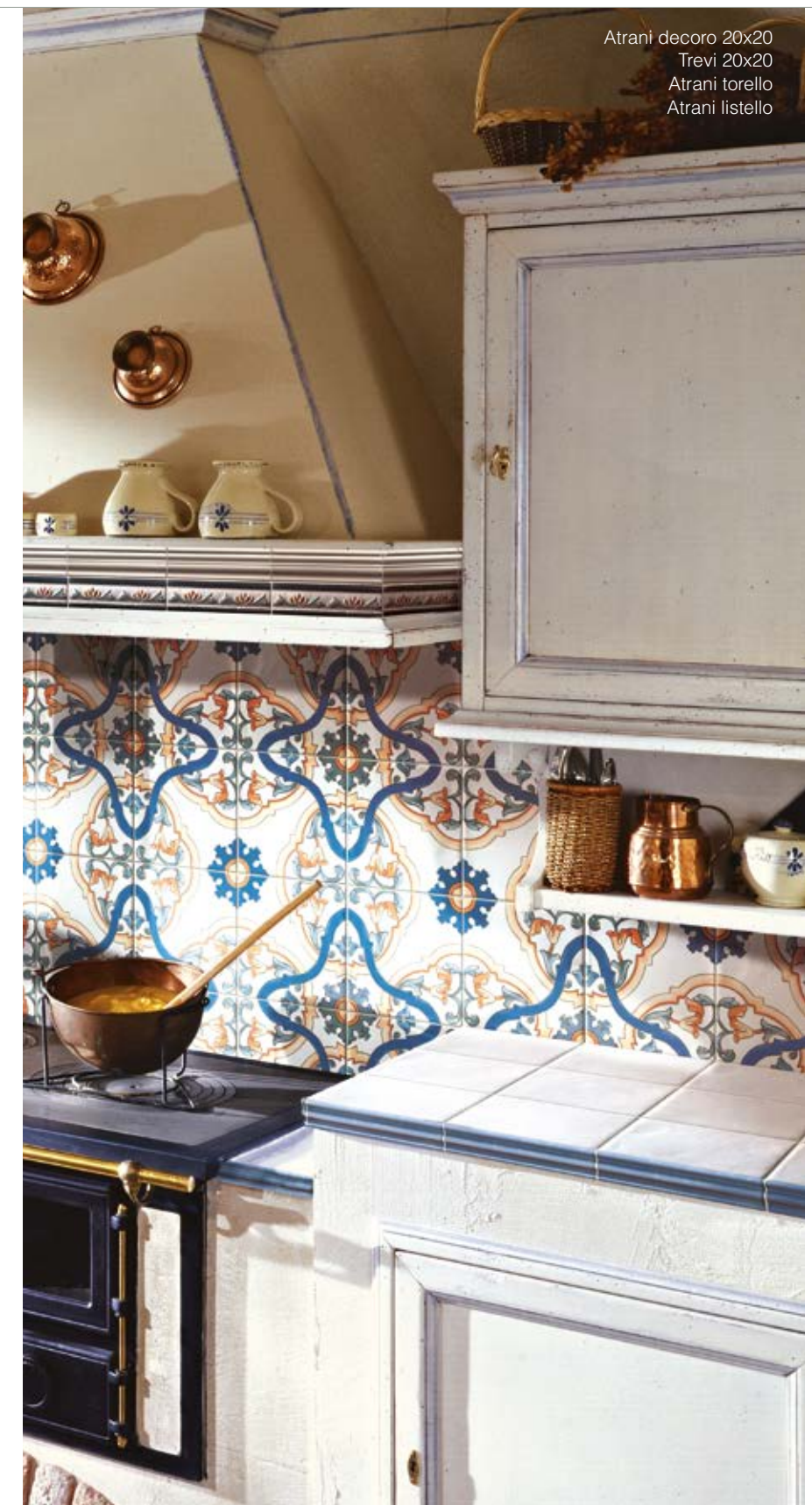

Atrani decoro 20x20
Trevi 20x20
Atrani torelo
Atrani listello



TAILORMADE

28x56^{11"x22"}

SHADE SPECTRUM

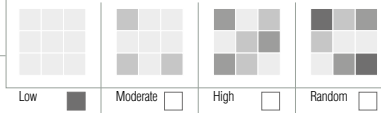

FORMATO	SPESSORE	Pzx	Mqx	Kgx	Mqx	Kgx
28x56	10	5	0,784	14,90	52	40,76
30x30	10,5	12	1,08	24,00	40	47,52
						774,80
						1077,00

TM10 BIANCO

TM20 BEIGE

TM05 GRIGIO

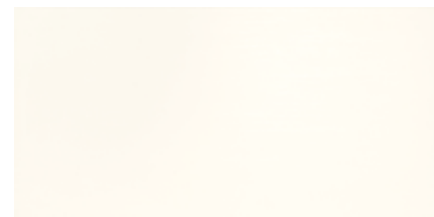

28x56 nat.

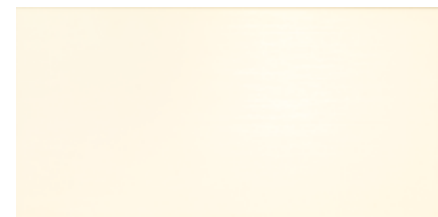

28x56 nat.



28x56 nat.

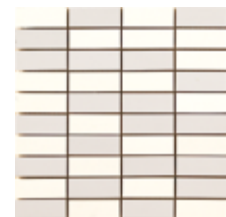

mosaico 5.10
28x28 (tessera 2,8x7)



dec provenzale 28x56 nat.



dec provenzale 28x56 nat.



dec provenzale 28x56 nat.

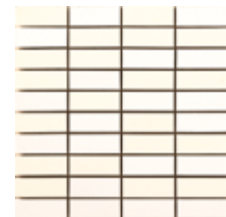

mosaico 10.20
28x28 (tessera 2,8x7)



fascia provenzale
25,5x3,5 nat.



fascia provenzale
25,5x3,5 nat.



fascia provenzale
25,5x3,5 nat.



fascia mix brown
30x2,5 nat.



fascia mix grey
30x2,5 nat.



SHADE SPECTRUM

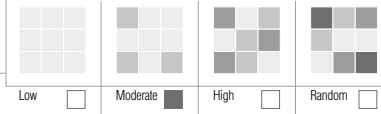

TAILORMADE

30x30^{12"x12"}



30x30 nat.



30x30 nat.



30x30 nat.



30x30 nat.



30x30 nat.

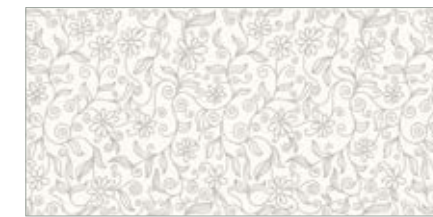

wallpaper 28x56 nat.

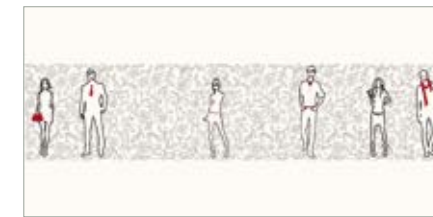

fascia people 28x56 nat.

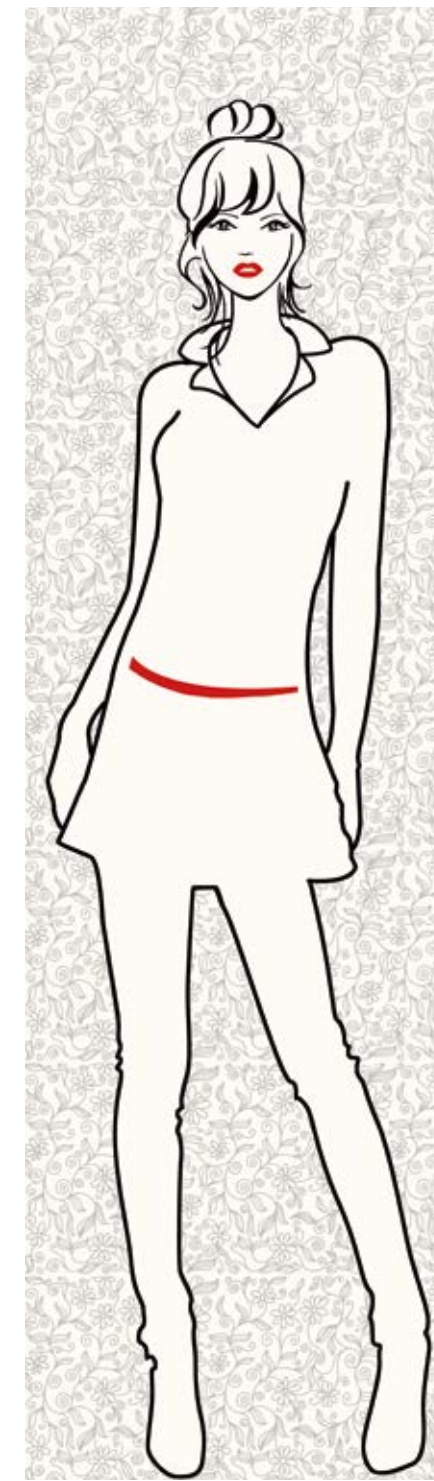

TM10 girl 196x56



(€ 615,00) 1 set

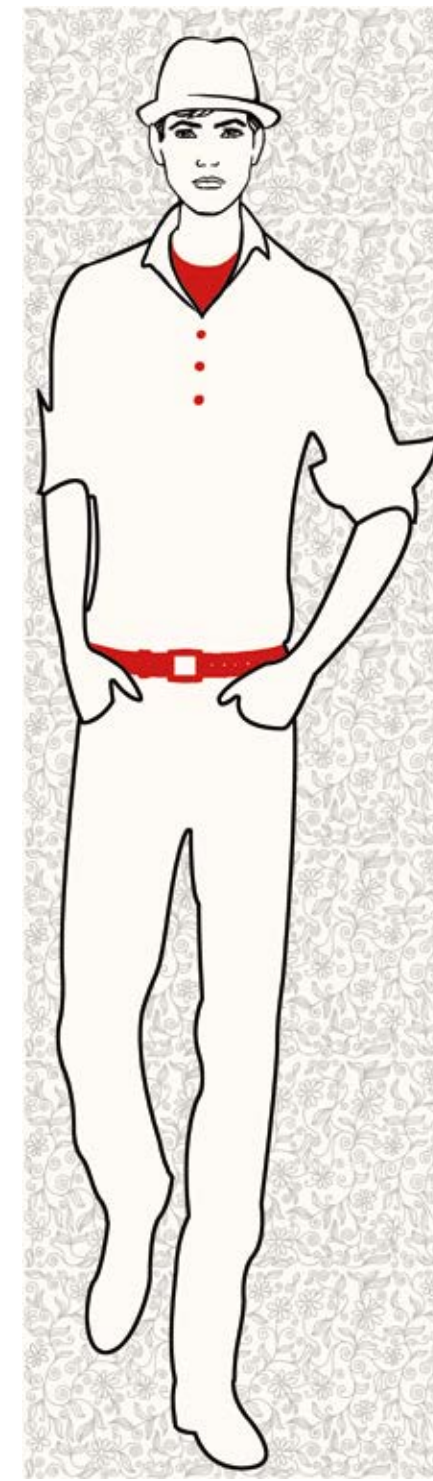

TM10 boy 196x56



(€ 615,00) 1 set

● DISPONIBILE NEI COLORI:
 TM10bianco e TM20beige
 Available in the colors: TM10bianco - TM20beige
 Disponibles dans les couleurs: TM10bianco - TM20beige
 In den Farben lieferbar: TM10bianco - TM20beige
 Disponible en colores: TM10bianco - TM20beige

TM mosaico 5.10



TM 10 Bianco 28x56 nat. TM fascia Mix Grey . TM 05 Grigio 28x56 nat.



TM 10 28x56 nat . TM 10 fascia People 28x56 nat.



GRES PORCELLANATO A TUTTO SPESSORE

FULL DEPTH VITRIFIED STONEWARE - GRÈS CERAME À TOUTE ÉPAISSEUR - FEINSTEINZEUG AUF GANZER DICKE - GRES PORCELÁNICO A TODO ESPESOR

**Pavimenti industriali resistenti al carico.
Pavimenti per uffici.**



Load resistant industrial flooring.

Office flooring.

Carrelages industriels résistants aux charges.

Carrelages pour bureaux.

Belastbare Industrieböden.

Büroböden.

Pavimentos industriales resistentes a la carga.

Pavimentos para oficina.

RESISTENZA all'ABRASIONE

*Abrasion Resistance
Résistance À L'abrasion
Abriebfestkeit
Resistencia A La Abrasión*

RESISTENZA al GELO

*Frost Resistance
Résistance Au Gel
Frostbeständigkeit
Resistencia Al Hielo*

RESISTENZA ai CARICHI di ROTTURA

*Breaking Load Resistance
Résistance Aux Charges De Rupture
Bruchlastbeständigkeit
Resistencia A Las Cargas De Ruptura*

RESISTENZA agli ACIDI

*Acid Resistance
Résistance Aux Acides
Säurefestkeit
Resistencia A Los Ácidos*

RESISTENZA agli URTI

*Impact Strength
Résistance Aux Chocs
Schlagfestkeit
Resistencia A Los Golpes*

RESISTENZA alle MACCHIE

*Stain Resistance
Résistance Aux Taches
Fleckenbeständigkeit
Resistencia A Las Manchas*

pastorelli

TRADIZIONALE

30x30^{12"x12"}. **PORFIRIZZATO** *unpolished.matt.mat.natural*

SHADE SPECTRUM

Low Moderate High Random

FORMATO	SPESSORE	Pz x	Mqx	Kgx	Mqx	Kgx
30x30	8,5	15	1,35	24,70	40	54,00
						988,00

DIASPRO.08

DIAMANTE.12



30x30 nat. 8,5 mm



30x30 nat. 8,5 mm



Pezzi SPECIALI

Special trims - Piezas especiales - Sonderstücke - Piezas especiales



● Gradino. 30x30 NAT. 49

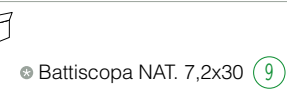

● Battiscopa NAT. 7,2x30 9

● DISPONIBILE IN TUTTI I COLORI

Available in all colours - Disponible dans toutes les couleurs - In allen Farben erhältlich - Se comercializas en todos los colores

pastorelli WallPaper

Pastorelli Wallpaper rappresenta il massimo livello del design e della tecnologia applicata alla decorazione artistica su carta delle pareti. Vere opere d'arte, realizzate da artisti e designer, caratterizzate da un grande livello di profondità e realismo.

Le collezioni Pastorelli Wallpaper sono realizzate con materiali completamente ecologici e sono concepite per essere abbinare ai pavimenti e rivestimenti ceramici Pastorelli. Il risultato è un incredibile effetto artistico-decorativo per tutti gli ambienti.

Pastorelli Wallpaper represents the highest level of design and technology applied to artistic decoration on wallpaper. Pure art masterpieces, realized by artists and designers, characterized by a high level of depth and realism.

Pastorelli wallpaper collections are realized with fully eco materials and are imagined to be combined with wall and floor Pastorelli products. The result is an amazing artistic-decorative effect for all environments.

Pastorelli Wallpaper représente le plus haut niveau de la conception et de la technologie appliquée à la décoration artistique sur papier peint. De véritables œuvres d'art, créées par des artistes et designers, caractérisées par un grand niveau de profondeur et de réalisme.

Les collections Pastorelli Wallpaper sont fabriqués avec des matériaux entièrement écologique et sont conçus pour être combinés avec le carrelage Pastorelli. Le résultat est un effet décoratif artistique incroyable pour tous les environnements.

Pastorelli Paper zeigt die höchste Stufe von Design, Technologie und künstlerische Dekoration auf Tapeten. Wahre Kunstwerke, geschaffen von Künstlern und Designern, gekennzeichnet durch einen hohen Grad an Tiefe und Realismus.

Die Kollektionen Pastorelli Paper werden mit absolut umweltfreundlichen Materialien hergestellt und sind für die Kombination mit Wand- und Bodenserien von Pastorelli konzipiert. Das Ergebnis ist eine unglaublich künstlerische und dekorative Wirkung für alle Ansprüche.



Total size: 584x290 cm



Moduli Elite

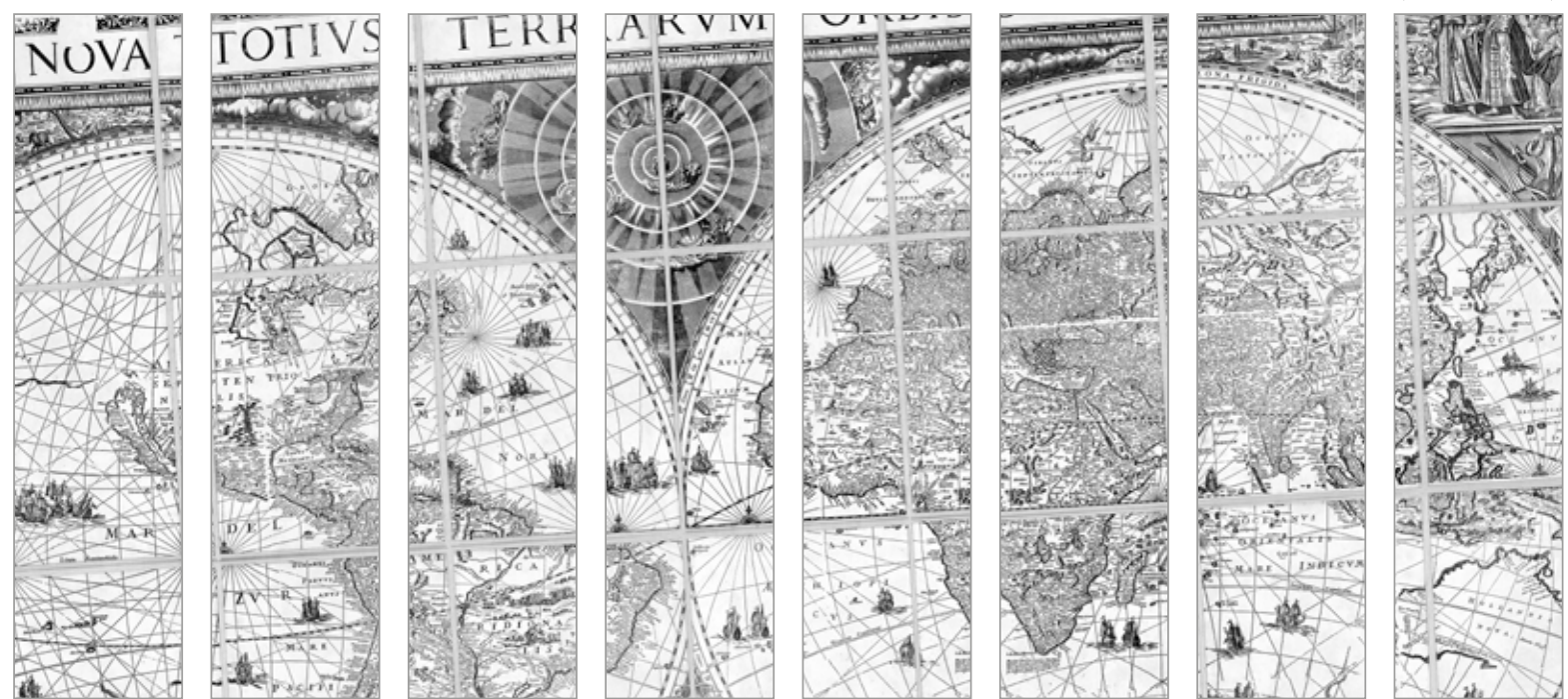

PWP EL1

PWP EL2

PWP EL3

PWP EL4

PWP EL5

PWP EL6

PWP EL7

PWP EL8

196 (€ 134,00)



SHADE WARM

Total size: 584x290 cm

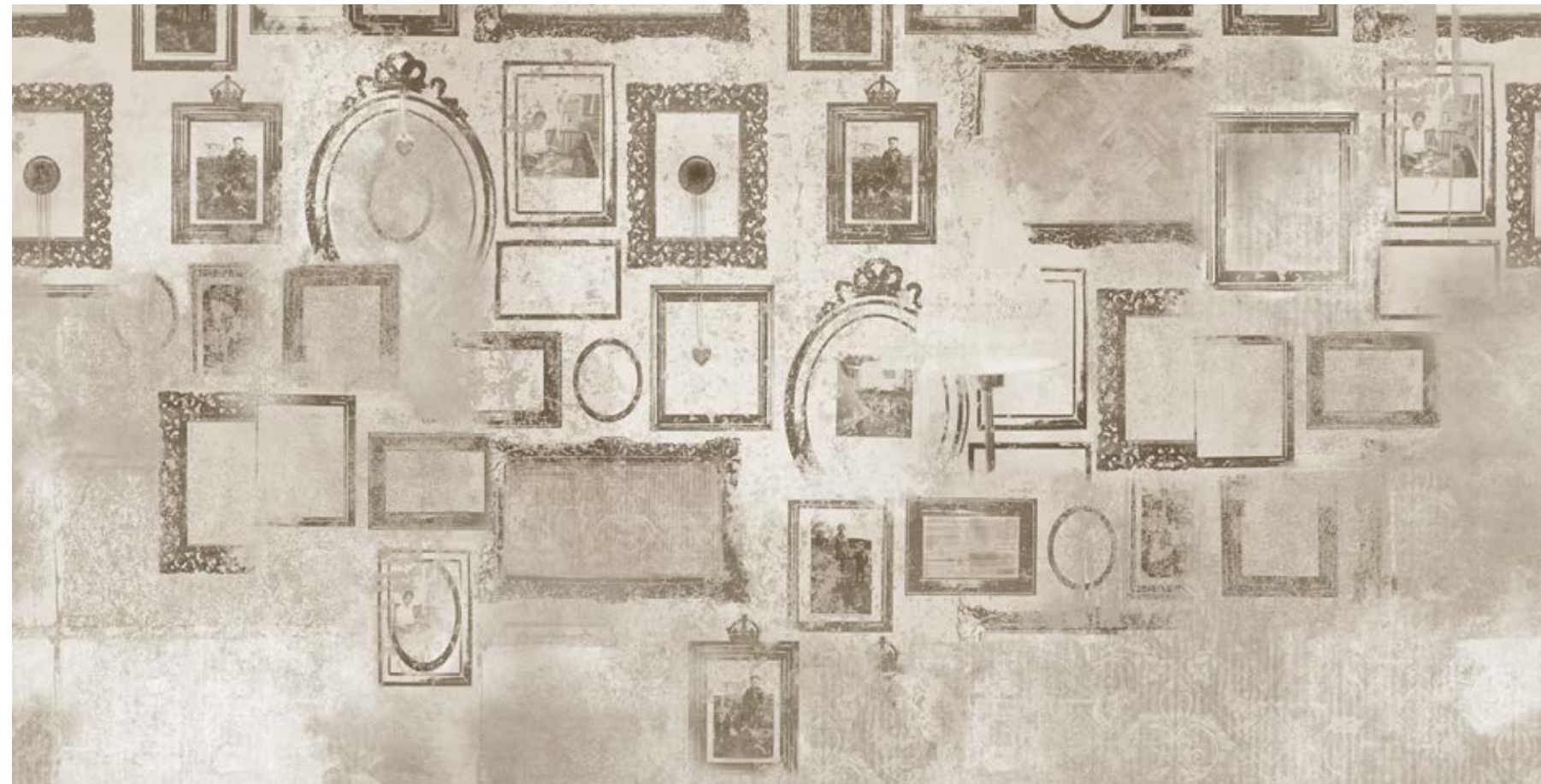

Moduli Shade Warm

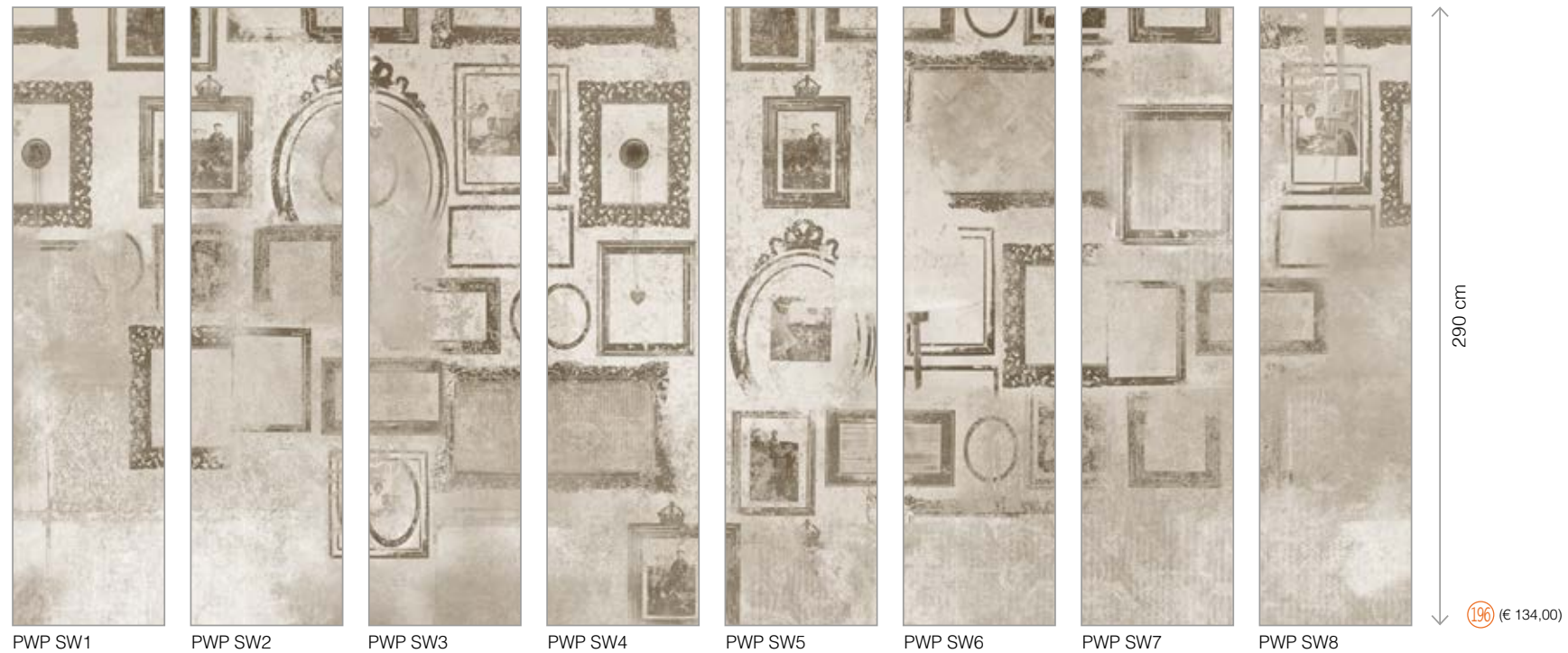

PWP SW1

PWP SW2

PWP SW3

PWP SW4

PWP SW5

PWP SW6

PWP SW7

PWP SW8



SHADE COLD

Total size: 584x290 cm

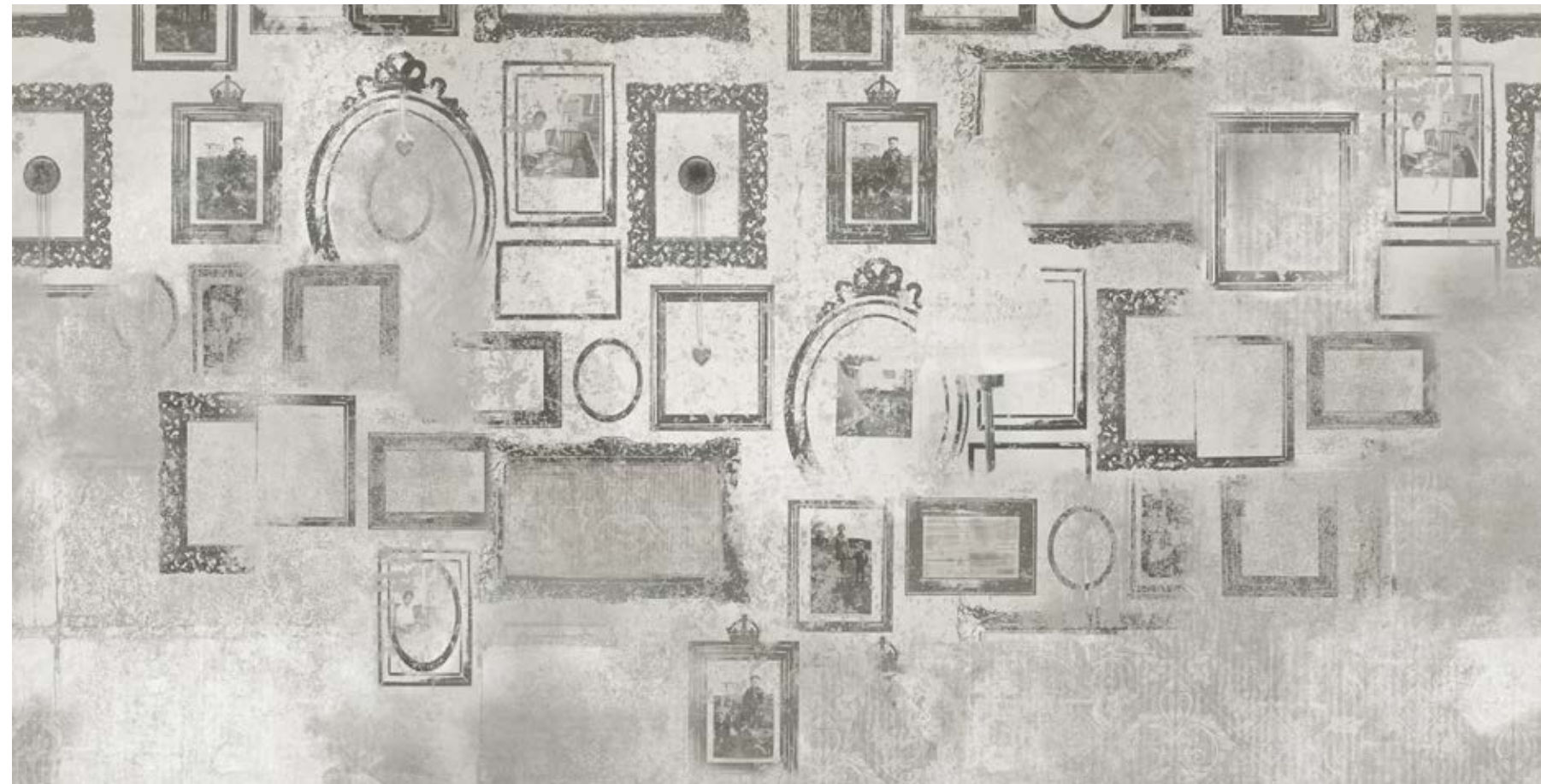

Moduli Shade Cold

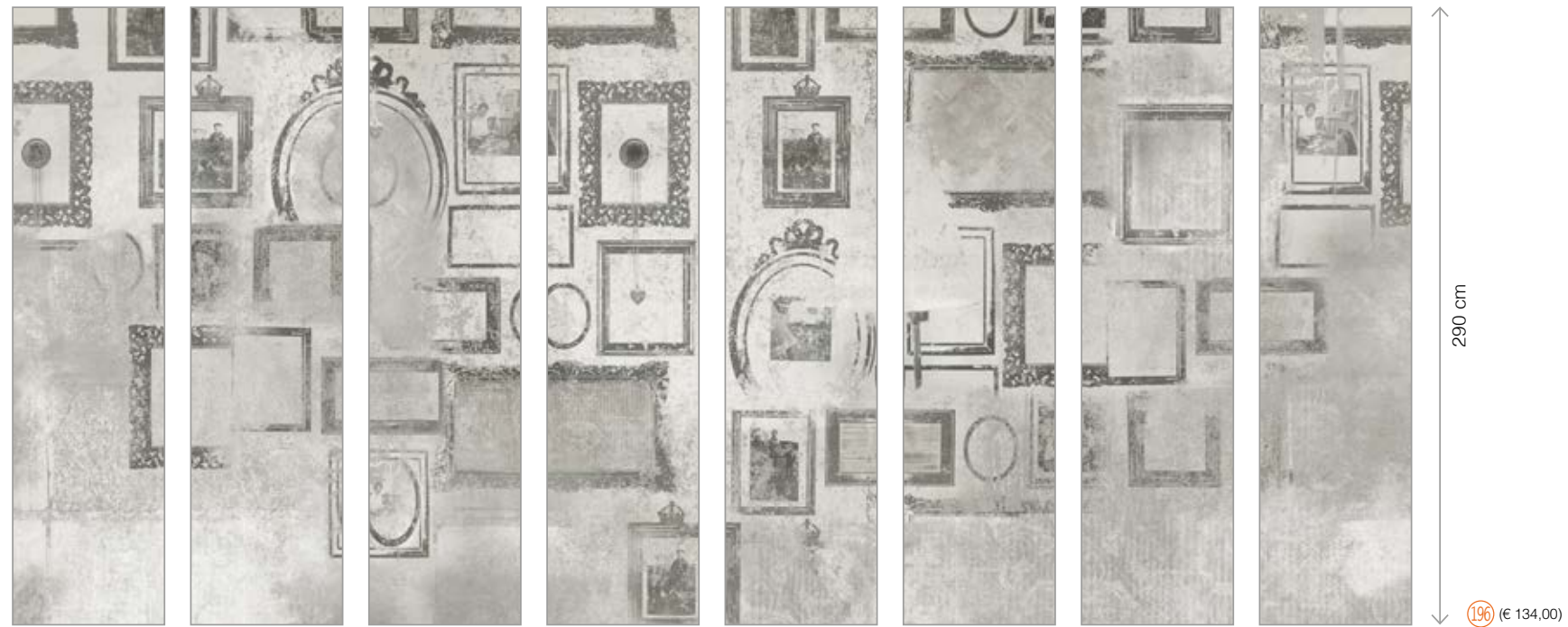

PWP SC1

PWP SC2

PWP SC3

PWP SC4

PWP SC5

PWP SC6

PWP SC7

PWP SC8



ATELIER WARM

Total size: 584x290 cm



Moduli Atelier Warm

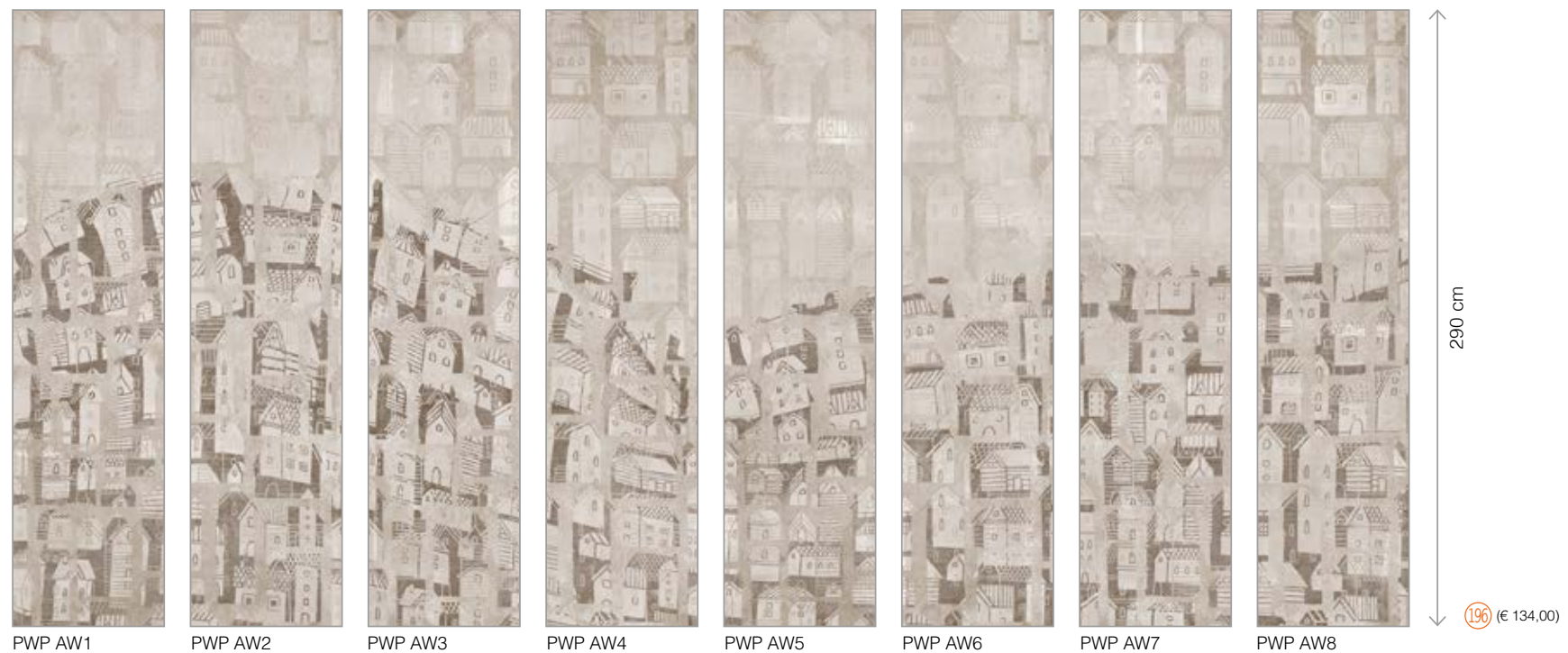

PWP AW1

PWP AW2

PWP AW3

PWP AW4

PWP AW5

PWP AW6

PWP AW7

PWP AW8



ATELIER COLD

Total size: 584x290 cm



Moduli Atelier Cold

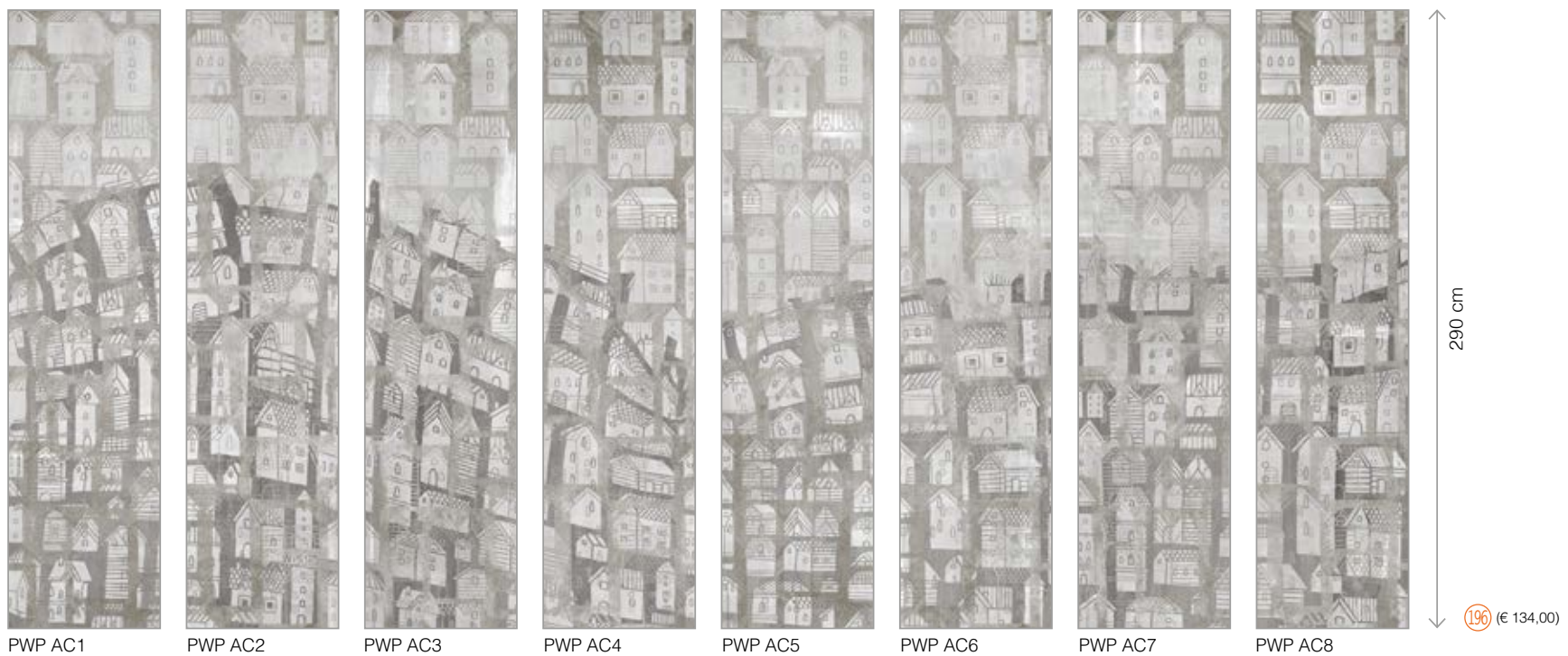

PWP AC1

PWP AC2

PWP AC3

PWP AC4

PWP AC5

PWP AC6

PWP AC7

PWP AC8



MILANO CITY WARM

Total size: 584x290 cm

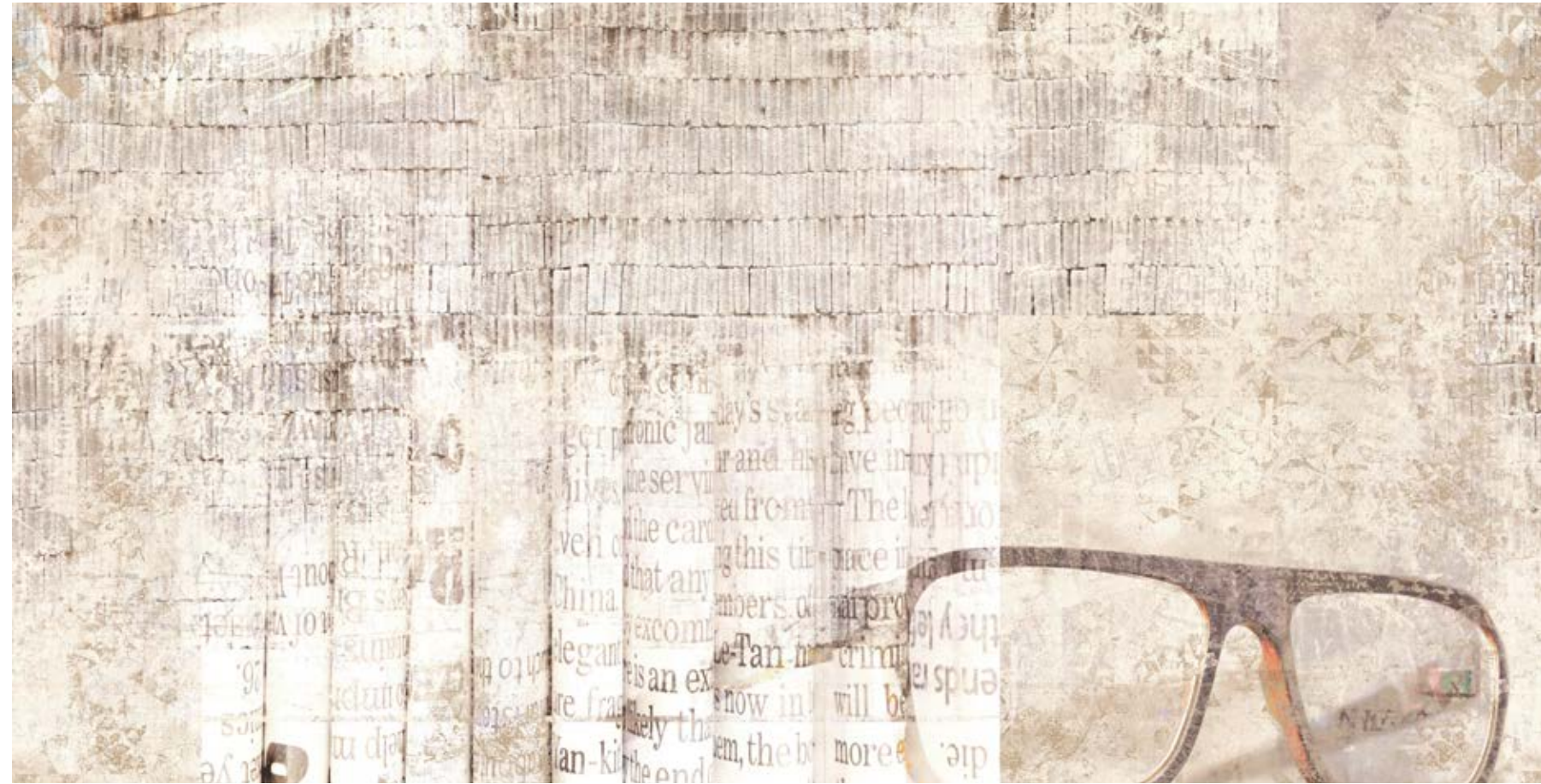

Moduli Milano City Warm



PWP MCW1

PWP MCW2

PWP MCW3

PWP MCW4

PWP MCW5

PWP MCW6

PWP MCW7

PWP MCW8



MILANO CITY COLD

Total size: 584x290 cm

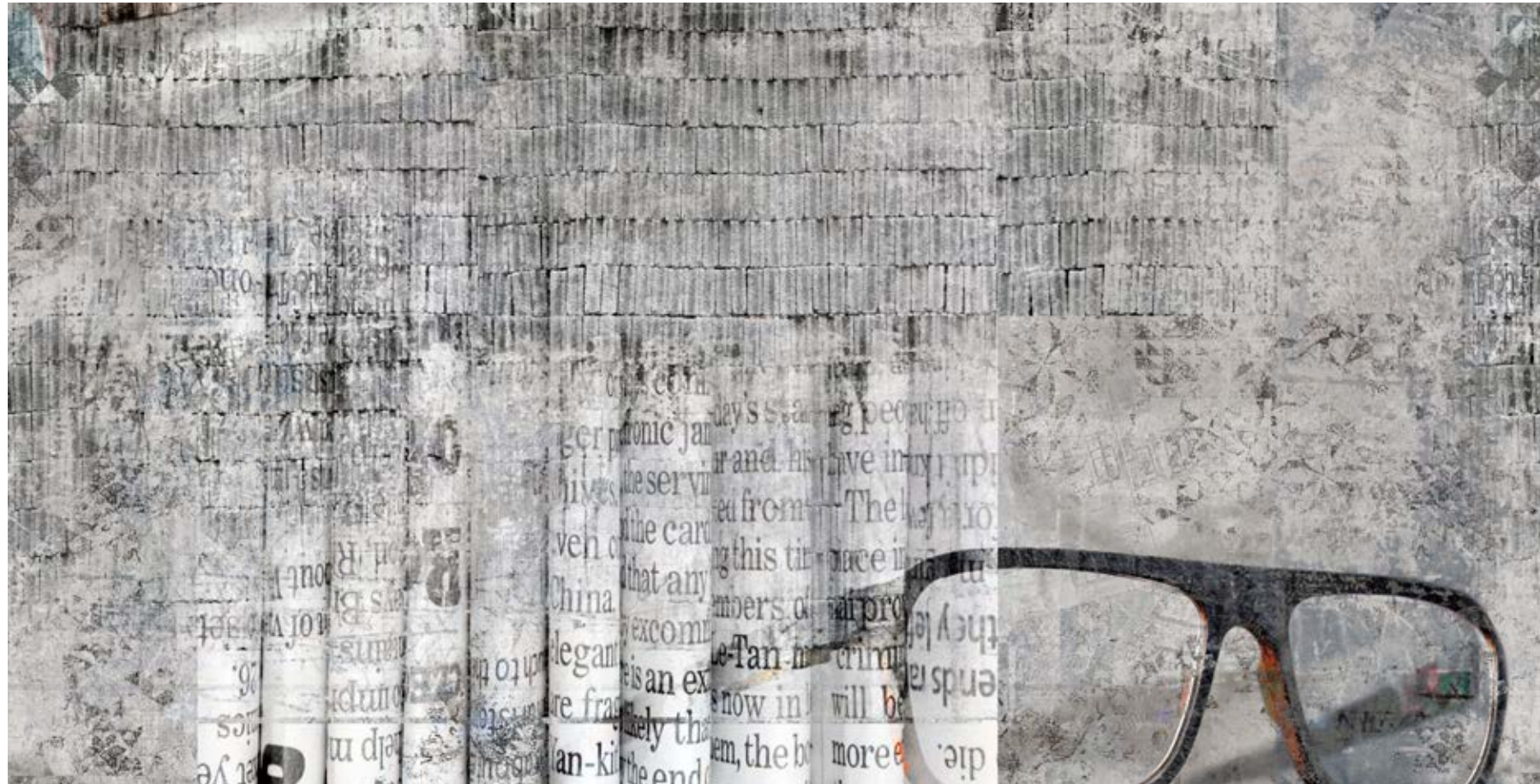

Moduli Milano City Cold

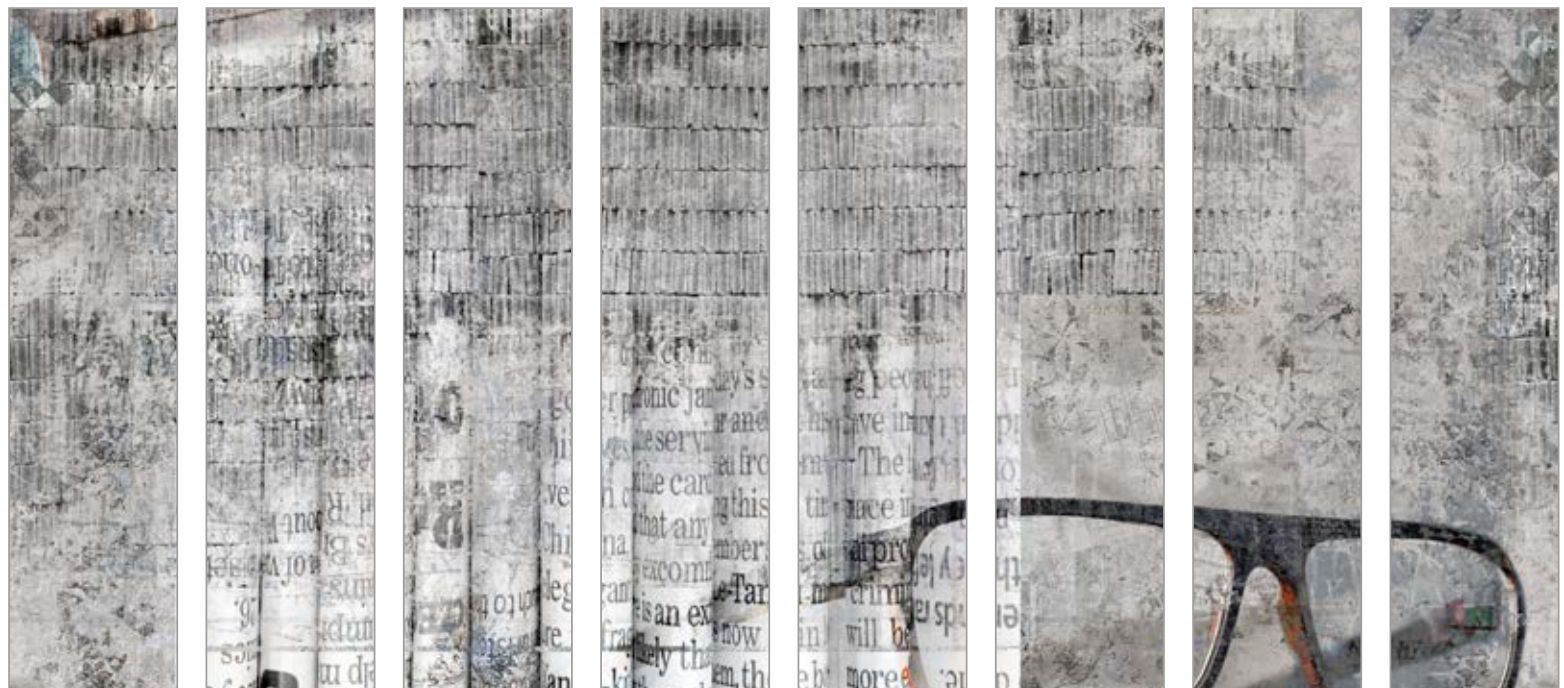

PWP MCC1 PWP MCC2 PWP MCC3 PWP MCC4 PWP MCC5 PWP MCC6 PWP MCC7 PWP MCC8

196 (€ 134,00)



PATINA WARM

Total size: 584x290 cm

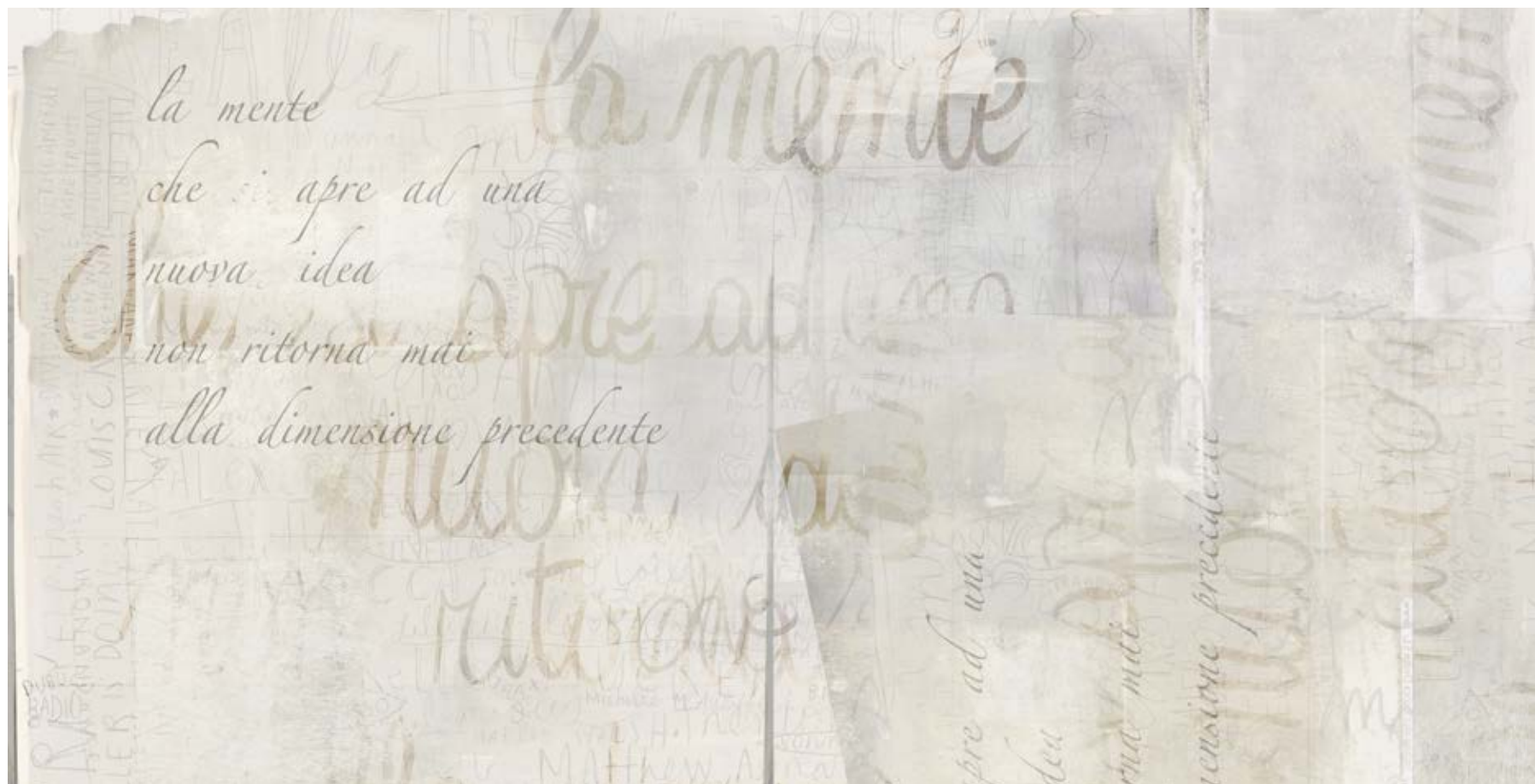

Moduli Patina Warm



PATINA WHITE

Total size: 584x290 cm

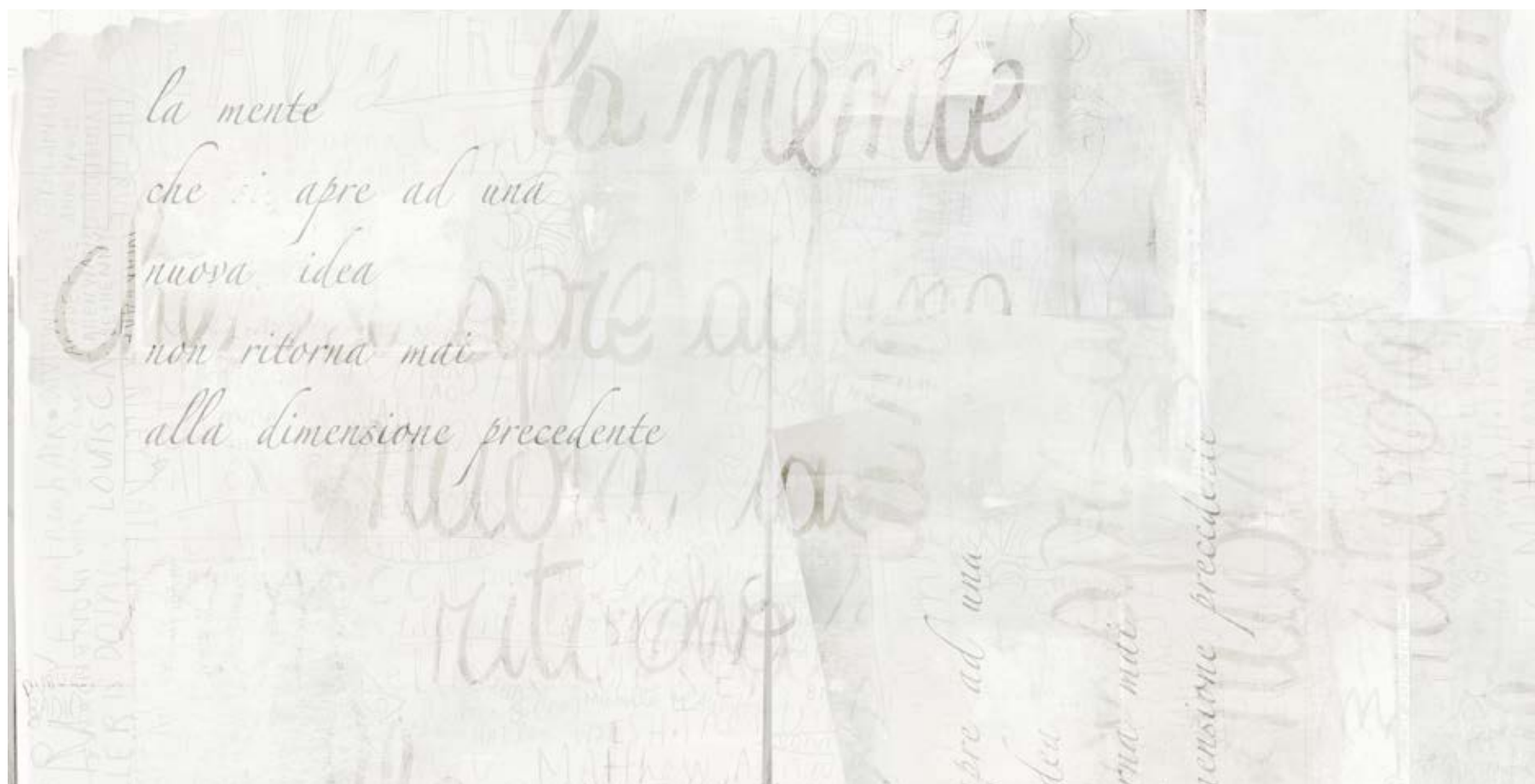

Moduli Patina White



MANHATTAN

Total size: 734x290 cm

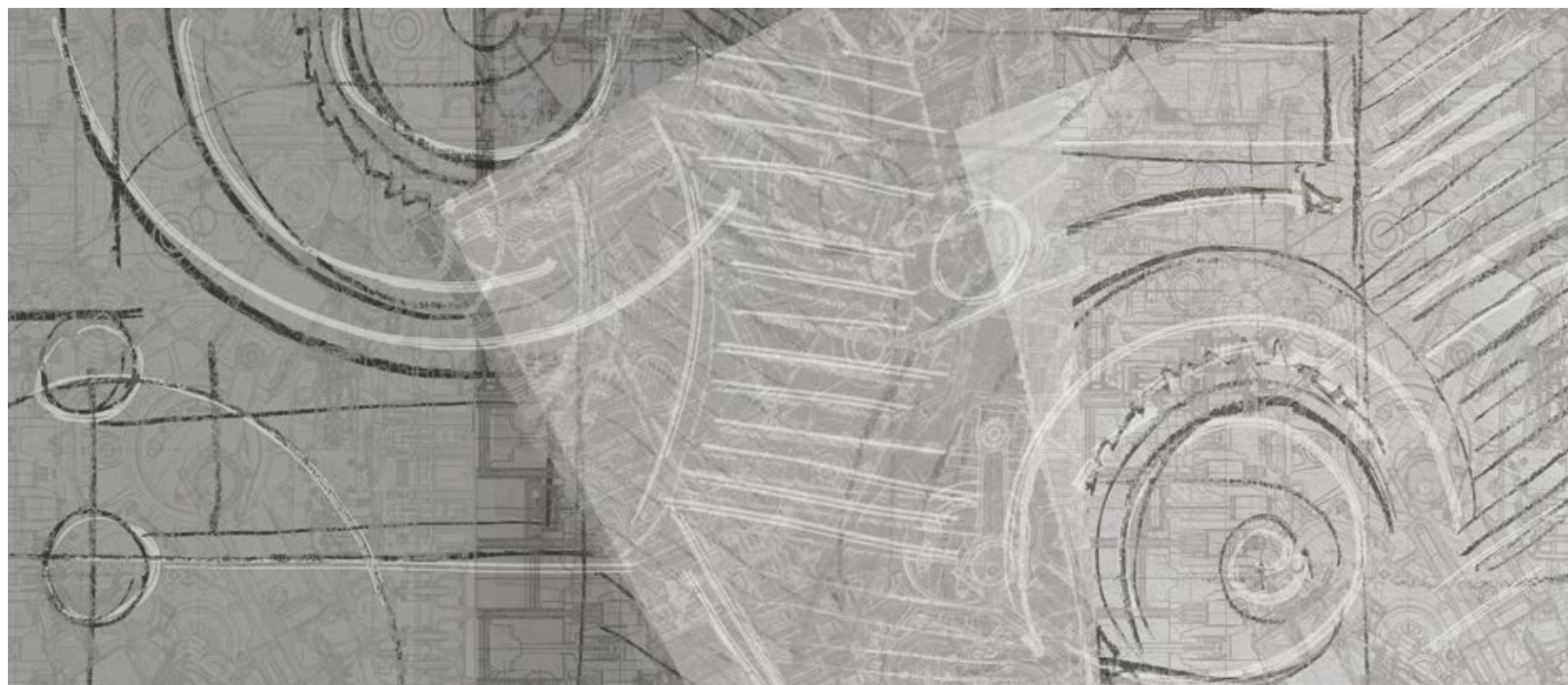

Moduli Manhattan



PWP MA1 PWP MA2 PWP MA3 PWP MA4 PWP MA5 PWP MA6 PWP MA7 PWP MAC8 PWP MA9 PWP MA10

196 (€ 134,00)



CARATTERISTICHE PRINCIPALI DI PASTORELLI WALLPAPER.

- Ignifuga.
- In regola con le normative europee sulla salute e sull'ambiente.
- Facilità di montaggio e rimozione grazie al supporto di spessore consistente.
- Lavabile con acqua e prodotti a base di sapone neutro.

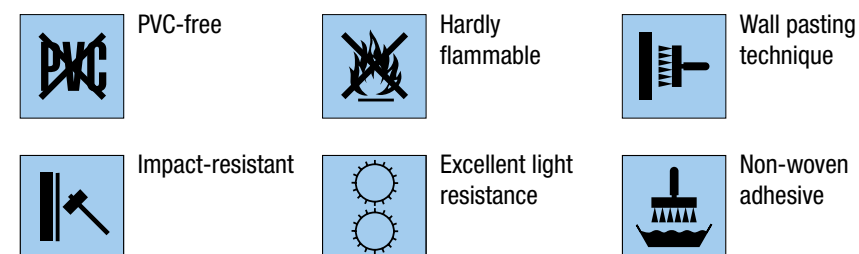
**POSA DI PASTORELLI WALLPAPER**

Per il montaggio a parete della vostra carta da parati è consigliabile affidarsi a un professionista. Tuttavia, se avete una buona manualità, è possibile procedere al fai da te.

Ecco di seguito i suggerimenti per un lavoro a regola d'arte in 6 passaggi:

- 1. Preparazione della parete.** La prima operazione da fare, una volta che avete scelto la parete dove collocare la vostra carta da parati, è ottenere una superficie completamente liscia e senza rugosità o difetti, in modo che la carta da parati aderisca in modo perfetto. Potete procedere con questa operazione raschiando la parete fino a che non sia pronta.
- 2. Preparazione della colla.** Acquistate nel vostro negozio di fiducia la colla gel adatta per la carta da parati. Procedete a versare la colla in un secchio, nella quantità di 200 g per metro quadro, e mescolate con una frusta (una di quelle adattabili al trapano) fino a che non spariscono eventuali grumi.
- 3. Applicazione della prima mano di colla.** Procedete poi a stendere in parete una mano la colla tramite un rullo. Lasciate asciugare per circa 20/30 minuti.
- 4. Stesura della carta.** Per prima cosa fate il piombo sulla parete, in modo da iniziare a posare correttamente la carta (ideale uno strumento laser che indichi perfettamente la linea con la quale iniziare). Poi, con davanti le indicazioni di posa del progetto, identificate il rotolo numero 2 e, calcolando che ogni rotolo ha una larghezza di 73 cm, posizionatelo come da figura, avendo cura di lasciare un margine di carta da rifilare successivamente nel rullo che andrà montato a sinistra, così da compensare difetti di perpendicolarità della parete. Procedete nello stesso modo con tutti gli altri rotoli, continuando a seguire le indicazioni di posa del progetto.
- 5. Applicazione della colla dopo la posa.** Una volta ultimato il posizionamento di tutti i rotoli procedete a stendere uno strato uniforme di colla gel, usando un pennello o una spatola. Applicare la colla gel senza diluirla, partendo dal primo rotolo, in modo uniforme e senza creare eccedenze di colla sulla superficie. Una volta terminata l'operazione rifilate con un cutter le eccedenze di carta da parati lungo tutto il perimetro della parete.
- 6. Applicazione protettivo finale.** Dopo circa 8 ore dalla stesura della colla gel sulla carta da parati, applicate uno strato di protettivo. Usate un pennello grande e realizzate una stesura uniforme su tutta la parete. Lasciare asciugare per circa 4 ore, quindi applicate una seconda mano di protettivo.

MAIN TECHNICAL FEATURES OF PASTORELLI WALLPAPER.

- Fireproof.
- In compliance with European regulations for healthcare and environmental conservation.
- Easy to hang and remove, thanks to the considerable thickness of its base.
- Washable with water and products based on mild soap.

**LAYING SCHEME OF PASTORELLI WALLPAPER**

It is advisable to ask to a professional in this field to fix the wallpaper on your surface. However, if you have a good manual skill, you can d.i.y.

Here-below you can find the suggestions to do the work in accordance with the highest professional standards, divided in 6 tips:

- 1. Preparation of the wall.** When you are choosing the surface to install the wallpaper, the first operation you have to do to obtain a complete flat surface, without any wrinkle or defect, is to make the wallpaper perfectly fit together with the wall. You can proceed with this operation, scratching out the surface until it is ready and flat.
- 2. Preparation of the glue.** You can buy the gel glue specific for wallpaper in your usual retail shop. Please proceed pouring the glue in a bucket, with a quantity of 200 gr/sqm and mesh it with a shaking tool (suitable for drill) until all the clots are completely disappeared.
- 3. First glue application.** Apply to the wall a first coat of glue using a paint roller. Leave it dry for about 20/30 minutes.
- 4. Wallpaper application.** Firstly put it in a perpendicular position on the wall, in order to begin laying the wallpaper properly (it is recommended to use a laser tool that can perfectly point out the line to begin with). Then, following the laying scheme's suggestions for the Project, identify the roller no. 2 and, calculating that each roller has an exact width of 73 cm, please position it like in picture no. 4, keeping in mind to leave a margin on the paper to be cut later on in the roller installed on the left side, to compensate the possible defects of perpendicularity on the wall. Please proceed in the same way with the other rollers, following the indications of relating laying scheme.
- 5. Glue application after the laying scheme.** Once the application of all rollers has been effected, please apply a compact coat of gel glue, using a paint brush or a spatula. Apply the glue without dilute it, starting from the first roller, in a uniform way, without creating any overflow. When this operation has been effected, trim with a cutter the extra parts of wallpaper along outer limit of the wall.
- 6. Application of final protection.** After about 8 hours from the application of the glue coat on the wallpaper, please apply also a final protection. Use a big brush and realize a compact layer on the wall. Let it dry for about 4 hours, then use a second application of final protection.

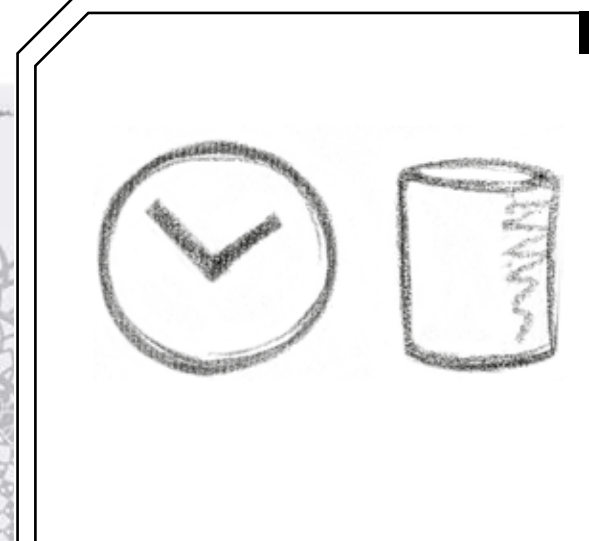
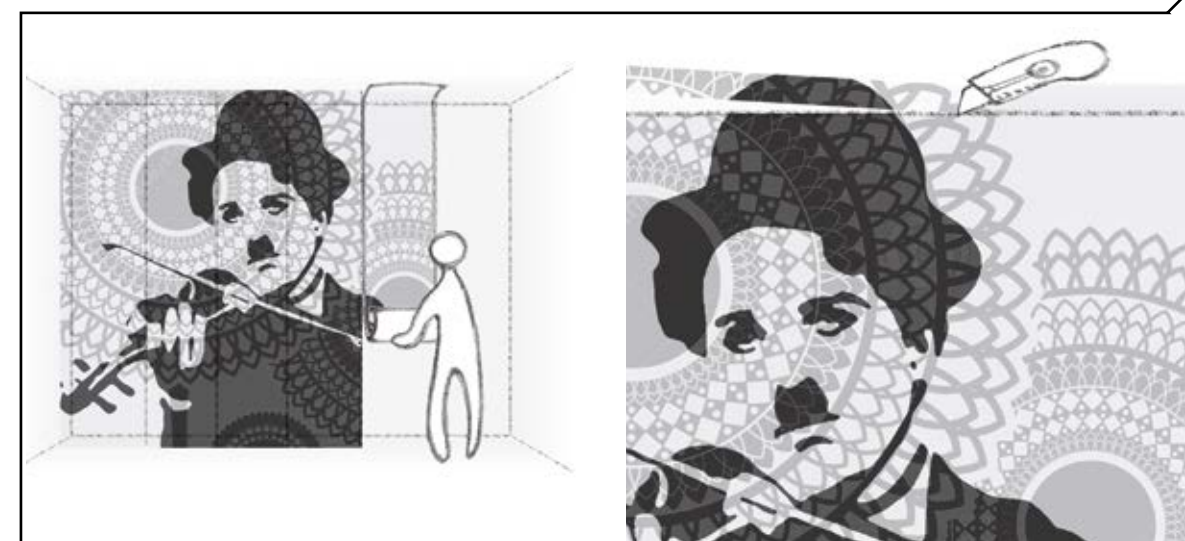
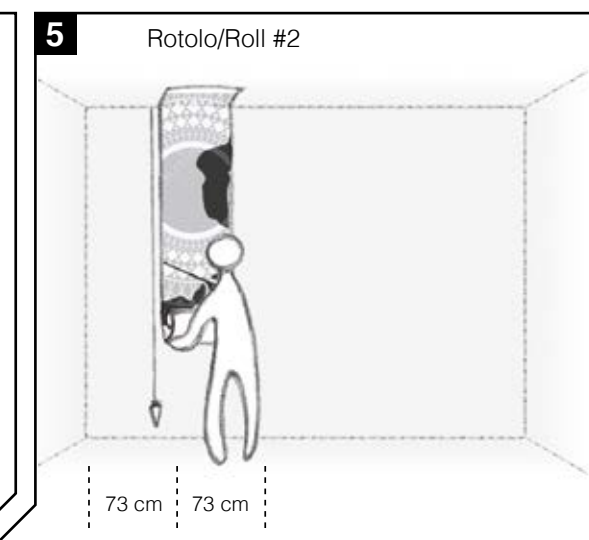
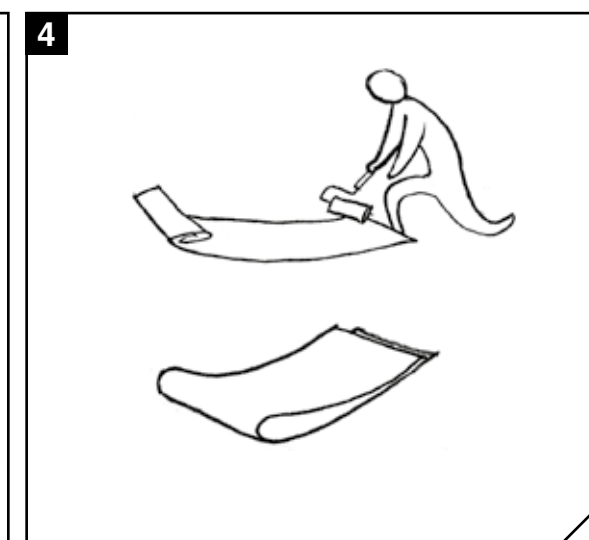
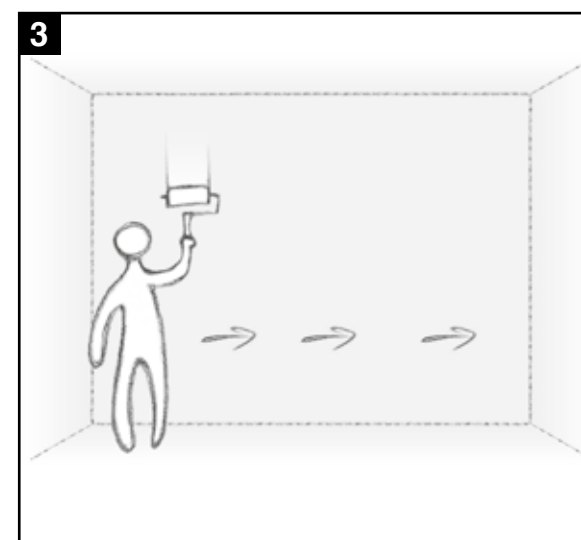
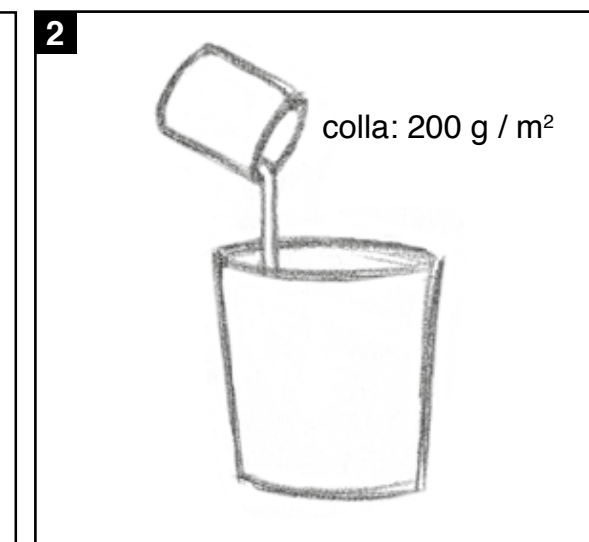
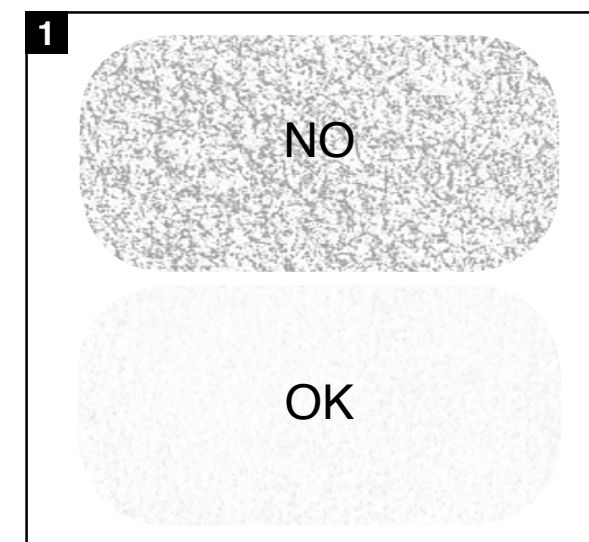

Informazioni tecniche

Technical data . Renseignements techniques
Technische Informationen . Informaciones técnicas



La posa del Modular System

La scatola del Modular SYSTEM facilita la posa creativa e naturale di più formati. Questa confezione dà la possibilità di numerose soluzioni di posa perché è composta da più formati. Tuttavia è possibile seguire uno o più schemi fissi basati sul contenuto di ogni scatola e ripetibili su grandi superfici.

LAYING THE MODULAR SYSTEM

The Modular SYSTEM box offers an easy solution for a creative and natural installation, combining different sizes. This packaging gives you the possibility to create several installation patterns thanks to the various sizes within the box. However, it is possible to follow one or more fixed patterns, which are based on the contents of each single box, and can be easily repeated on large surfaces.

LA POSE DU MODULAR SYSTEM

Le kit Modular SYSTEM permet la pose créative et naturelle de plusieurs formats. Ce kit offre de nombreuses solutions de pose car il est composé par différents formats. Il est toutefois possible de suivre un ou plusieurs schémas fixes de pose, basés sur le contenu de chaque boîte, également valables pour les grandes surfaces.

DIE VERLEGUNG DES MODULAR SYSTEM

Der Inhalt des Kartons Modular SYSTEM vereinfacht die kreative Verlegung, bietet die Möglichkeit einer kreativen und naturalen Verlegung von verschiedenen formaten. Man kann einer der auf dem Karton angegebenen Verlegungsarten wählen, die sich leicht auf grosse oberflächen uebertragen lassen.

LA COLOCACIÓN DEL MODULAR SYSTEM

La caja del Modular SYSTEM facilita la posa creativa y natural de una pluralidad de formatos. Dicho embalaje ofrece la posibilidad de numerosas soluciones de posa en cuanto está compuesto por mas formatos. Sin embargo, es posible seguir uno o mas esquemas fijos según el contenido de cada caja y repetibles sobre grandes superficies.

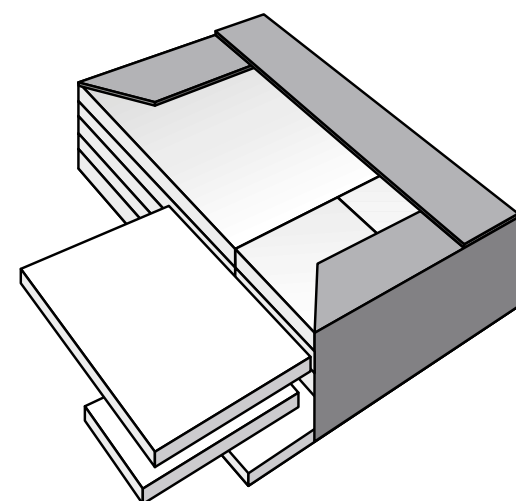

SERIE: Marmi Antichi

Modular SYSTEM

3 Pz. 45x45
2 Pz. 30x30
10 Pz. 15x15

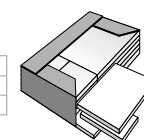

SPECIALE CONFEZIONE
MODULARE A 15 PEZZI
Special Modular packaging 15 pcs.
Emballage special 15 pcs.
Sonder Verpackung 15 stck.
Embalaje especial modular con 15 piezas.

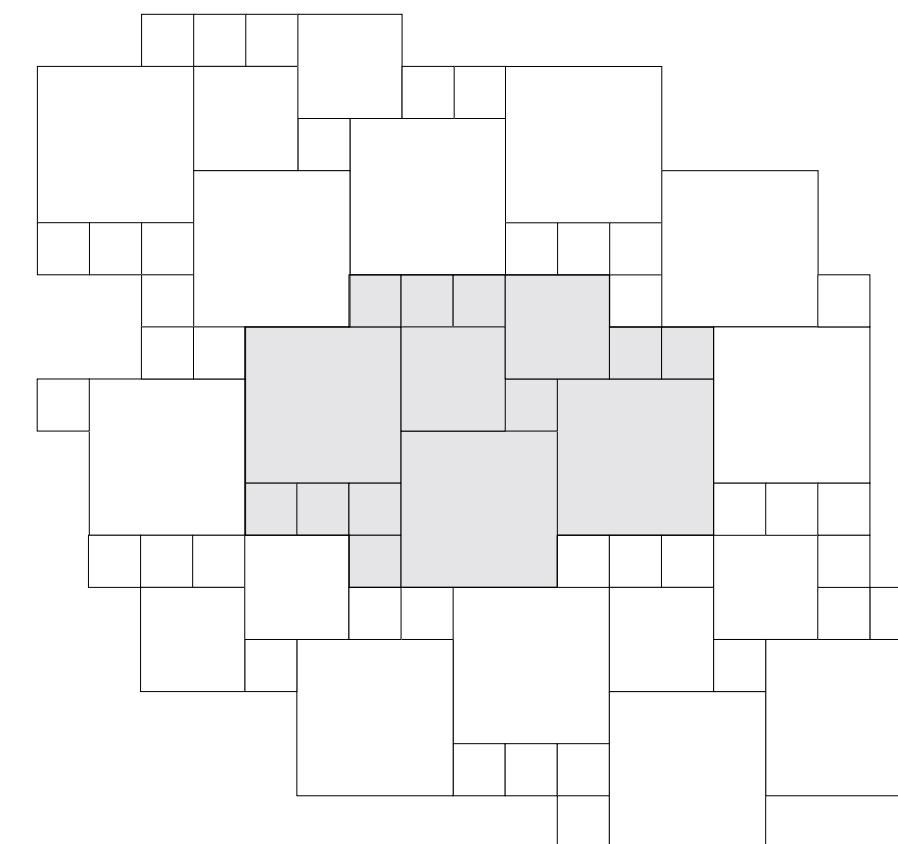

PEZZI SPECIALI

Special trims - Pieces especiales - Sonderstücke - Piezas especiales

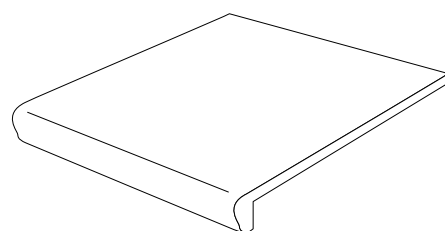

Gradone "pressato"
SERIE: Terre Senesi

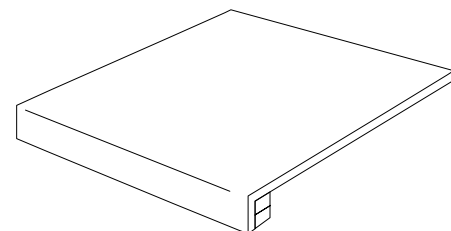

Gradone "assemblato"
SERIE: Antiche Doghe, Himalaya, Lithos, Pierre Royale, Quarz Design, V.360, Milano City, Country Life, Elite, Madera, Shade, Atelier.

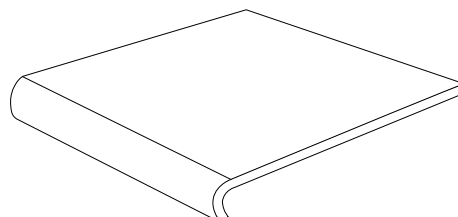

Gradone lineare
SERIE: Tailormade

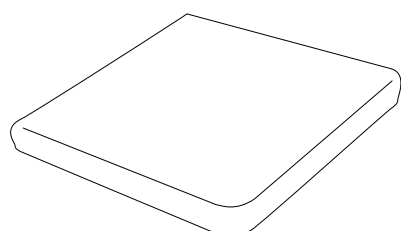

Gradone angolare "pressato"
SERIE: Terre Senesi

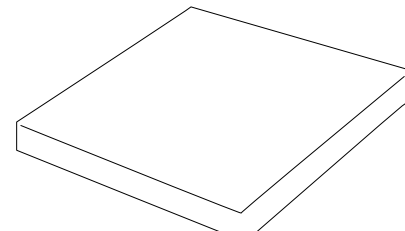

Gradone angolare "assemblato"
SERIE: Himalaya, Lithos, Pierre Royale, Quarz Design, V.360, Milano City, Elite, Shade.

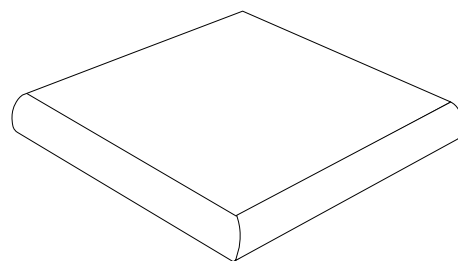

Gradone angolare
SERIE: Tailormade

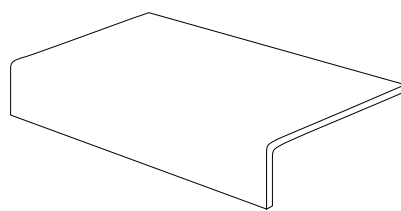

Elemento ad L monolitico "pressato"
SERIE: Ayers Rock, Duomo

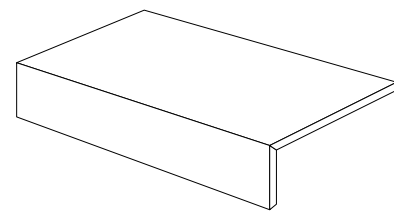

Elemento ad L "assemblato"
SERIE: Pierre Royale

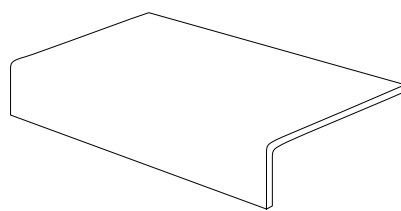

Elemento ad L "monolitico"
SERIE: Himalaya, Quarz Design, V.360

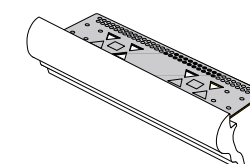

Profilo gradino
SERIE: Duomo, Loft, Manhattan, Marfil, Villa Imperiale

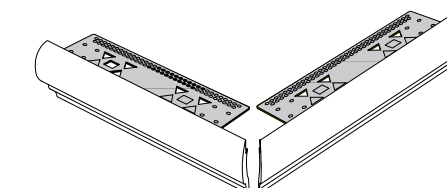

Angolo profilo gradino
SERIE: Duomo, Loft, Manhattan, Marfil, Villa Imperiale



Materiali non sottoposti a sollecitazioni meccaniche (es. bordi perimetrali di balconi, di terrazze, di sommità di muretti ecc...
Il bordo verticale non deve aderire alla malta o alla colla ma deve essere distanziato di 5-10 mm.

*Areas not subjected to mechanical stress (for example, the perimeter edges of balconies and terraces, tops of low walls etc...)
The vertical edging must not adhere to the mortar. Or the adhesive, but must be clear of it by 5-10 mm.*



*Zones soumises à des pressions mécaniques (par exemple, les extrémités des balcons, terrasses murets, ect...)
Le bord vertical ne doit pas être enduit de ciment ou de colle. Veiller à laisser un espace de 5-10 mm.*

*Keinen mechanischen Beanspruchungen unterliegende Materialien (z.B.: umlaufender Rand von Balkons, Terrassen, Mauerabschlüssen, usw.)
Der senkrechte Rand darf nicht am Mörtel oder Kleber haften sondern muss einen Abstand von 5-10 mm aufweisen.*

*Materiales no sometidos a obstáculos metalicos (ej. Borde perimetrico de los balcones, terrazas, etc...)
El borde vertical no se debe pegar a la argamasa o a la cola. Pero tiene que estar distanciado unos 5-10 mm.*

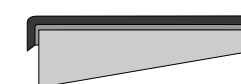

Materiali sottoposti a sollecitazioni meccaniche (es. bordi di gradini, marciapiedi, ecc...
Nella fase di posa degli elementi piegati evitare vuoti di colla o di malta nella zona d'angolo interno.

*Areas subject to mechanical stress (for example the edges of steps, pavements etc...)
During laying, avoid leaving voids in the bed of the tile.*



*Zones soumises à des pressions mécaniques (par exemple, les extrémités des marches, trottoirs, etc...)
Lors de la pose, ne pas laisser d'espaces vides sous la dalle; pour la pose avec de la colle, utiliser la technique de la "double enduction".*

*Mechanischen Beanspruchungen unterliegende Materialien (z.B. Rand von Stufen, Fußwegen, usw. ...)
Bei der Verlegung der gebogenen Elemente Hohlräume im Kleber oder Mörtel im Bereich des Innenwinkels vermeiden.*

*Materiales sometidos a obstáculos metalicos (ej. Bordos de peldaños, aceras, etc...)
En la fase de colocacion de las piezas dobladas, se Tienen que evitar los vacios de cola o argamasa en la zona del angulo interno.*

SCHEMI DI POSA

Laying patterns - Schémas de pose - Verlegungsschemen - Esquemas de colocación

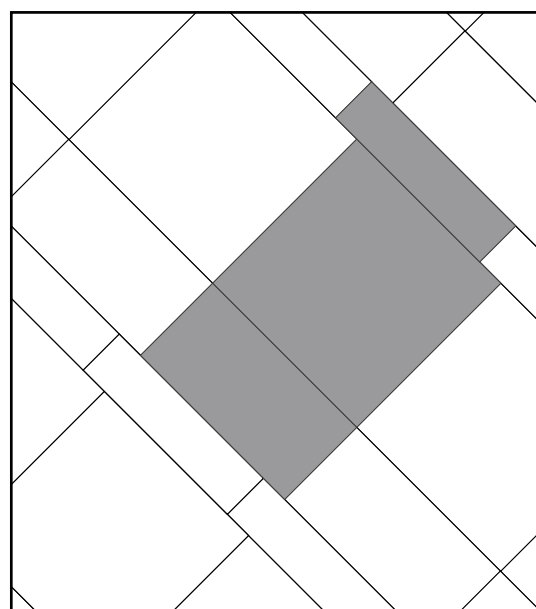

FORMATO - SIZES	%
15x60	2%
30x60	28,6%
60x60	57,1%

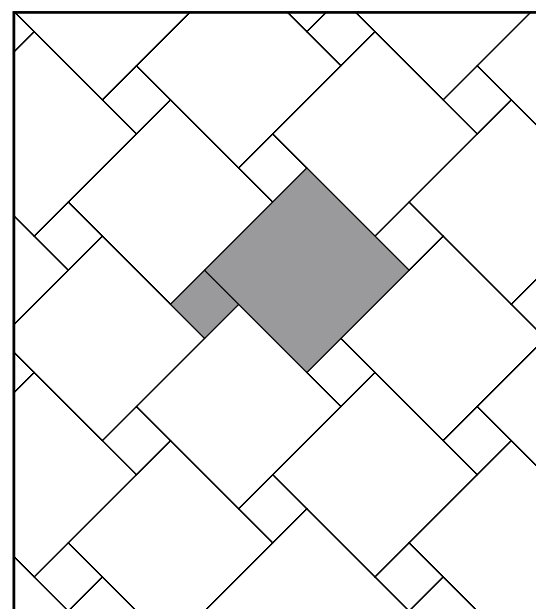

FORMATO - SIZES	%
15x15	10%
45x45	90%

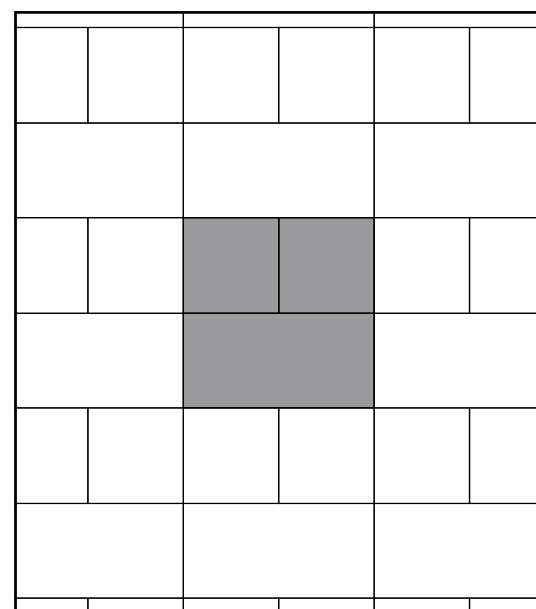

FORMATO - SIZES	%
20x20	50%
20x40	50%

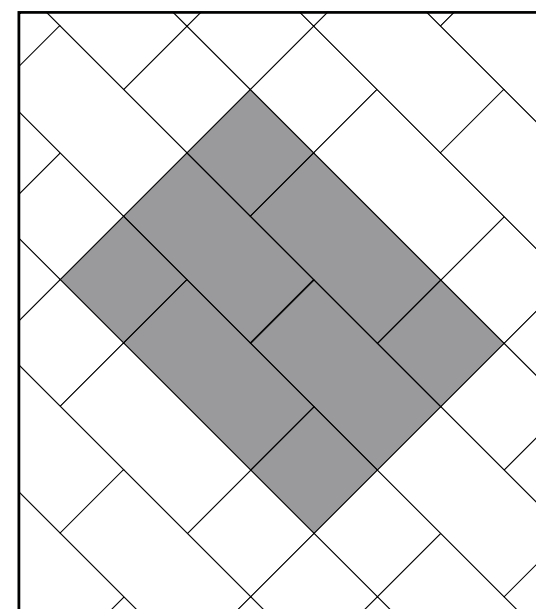

FORMATO - SIZES	%
20x20	33%
20x40	67%

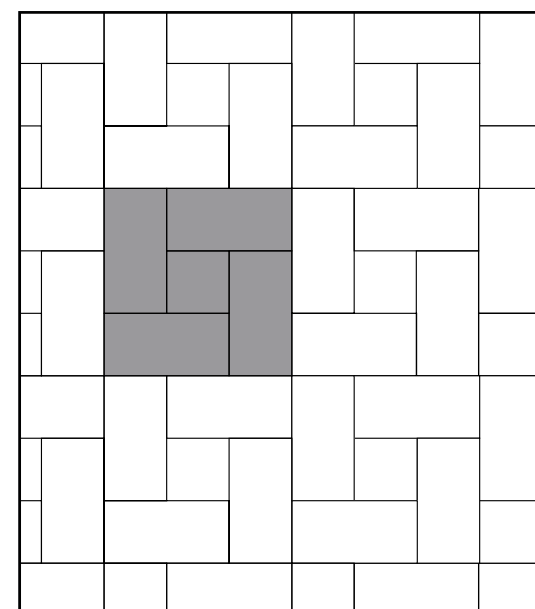

FORMATO - SIZES	%
30x30	11,1%
30x60	88,9%

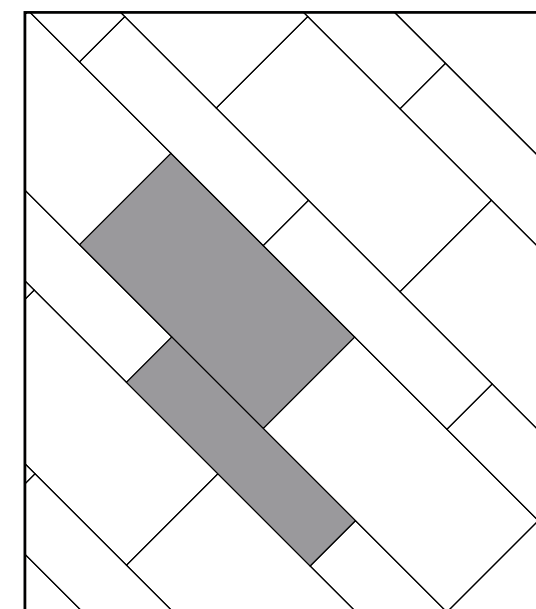

FORMATO - SIZES	%
40x80	66,6
20x80	33,4

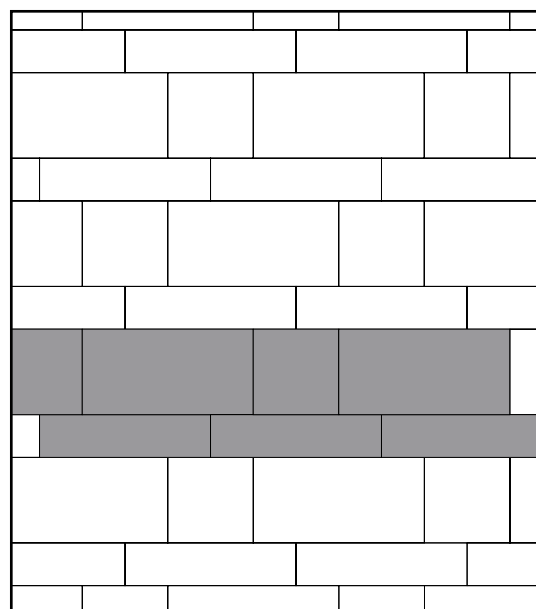

FORMATO - SIZES	%
15x60	33%
30x60	45%
30x30	22%

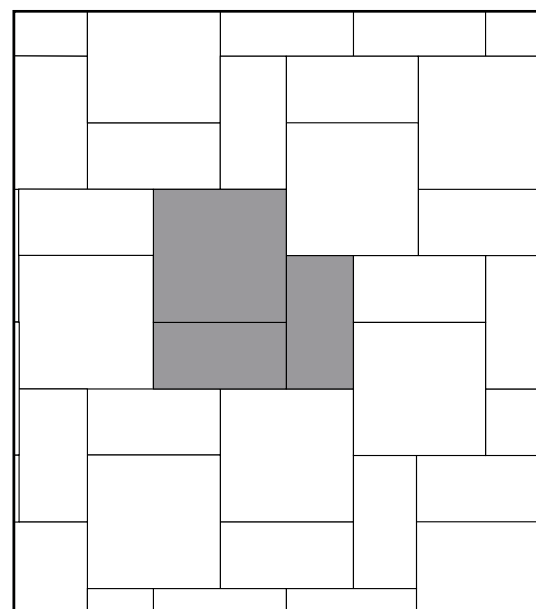

FORMATO - SIZES	%
30x60	50%
60x60	50%

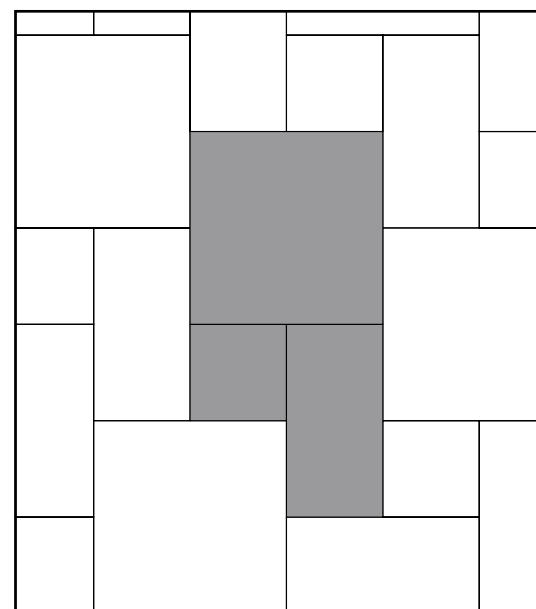

FORMATO - SIZES	%
30x30	14%
30x60	29%
60x60	57%

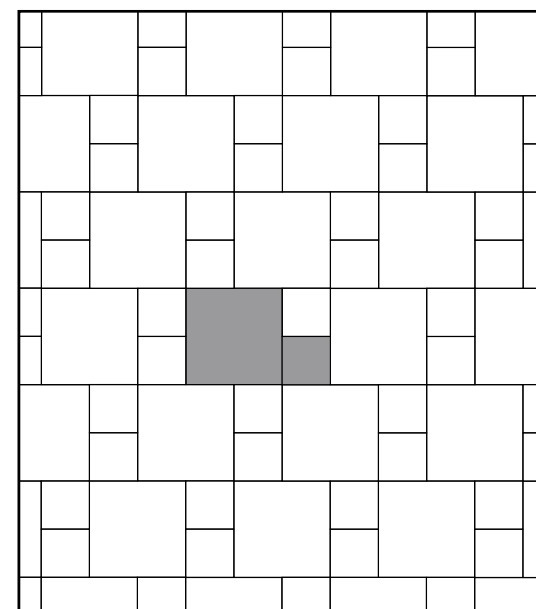

FORMATO - SIZES	%
30x30	66,6
15x15	33,4

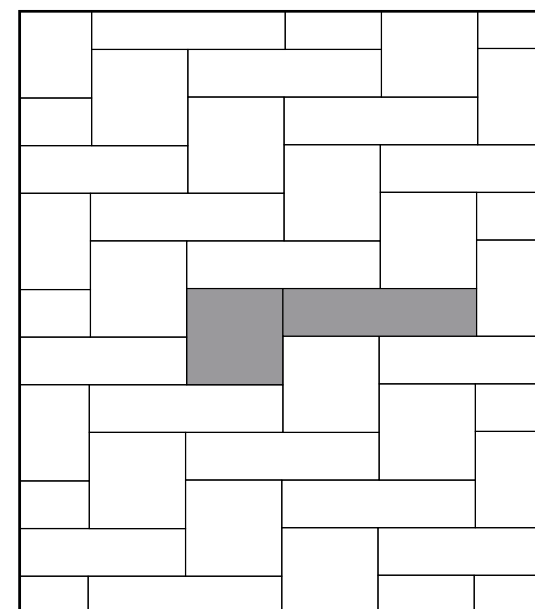

FORMATO - SIZES	%
30x30	50
15x60	50

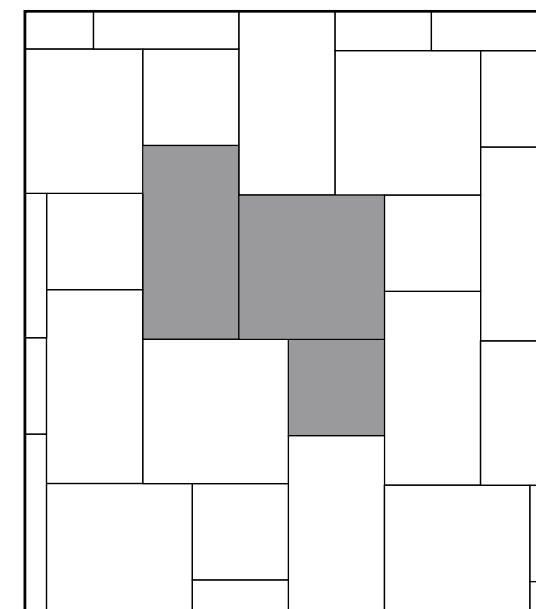

FORMATO - SIZES	%
30x30	22,2%
30x60	44,4%
45x45	33,4%

SCHEMI DI POSA

Laying patterns - Schémas de pose - Verlegungsschemen - Esquemas de colocación

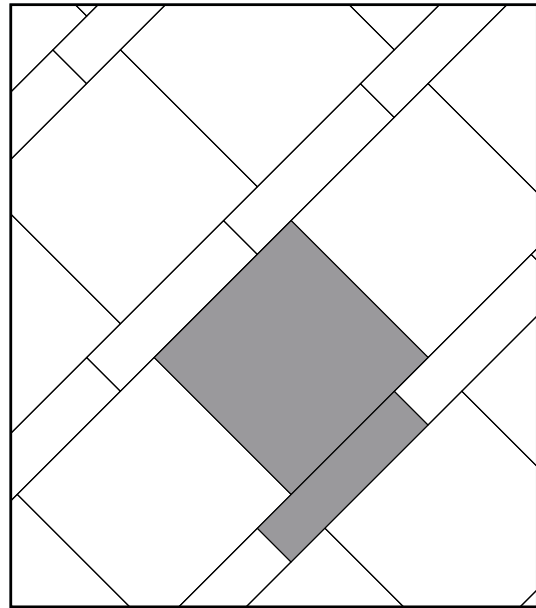

FORMATO - SIZES	%
60x60	80
15x60	20

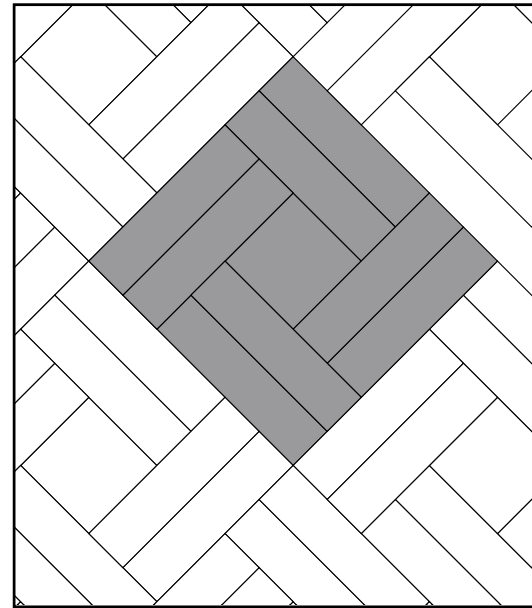

FORMATO - SIZES	%
30x30	11,1%
15x60	88,9%

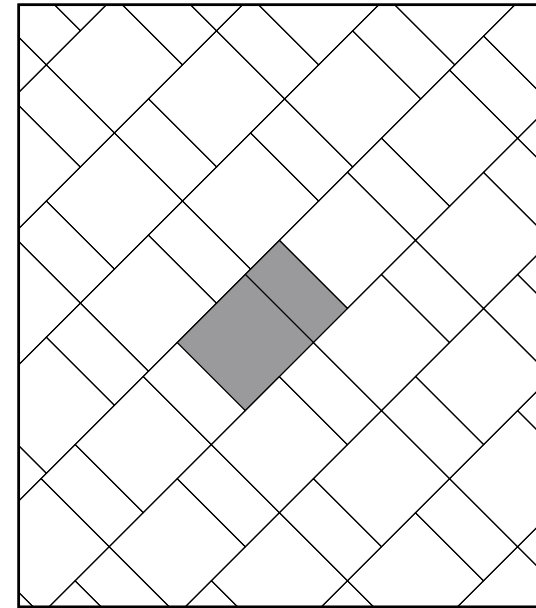

FORMATO - SIZES	%
30x30	66,6
15x30	33,4

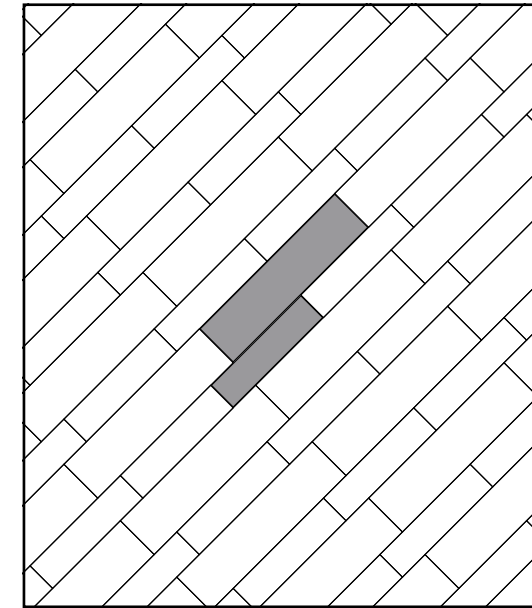

FORMATO - SIZES	%
20x80	30,77
30x120	69,23

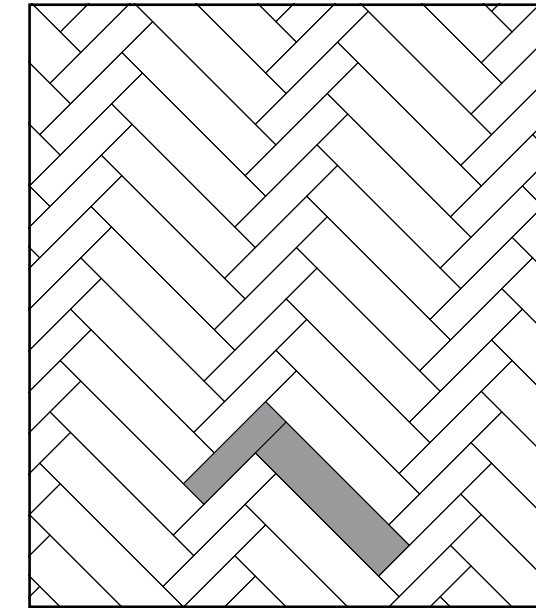

FORMATO - SIZES	%
20x80	30,77
30x120	69,23

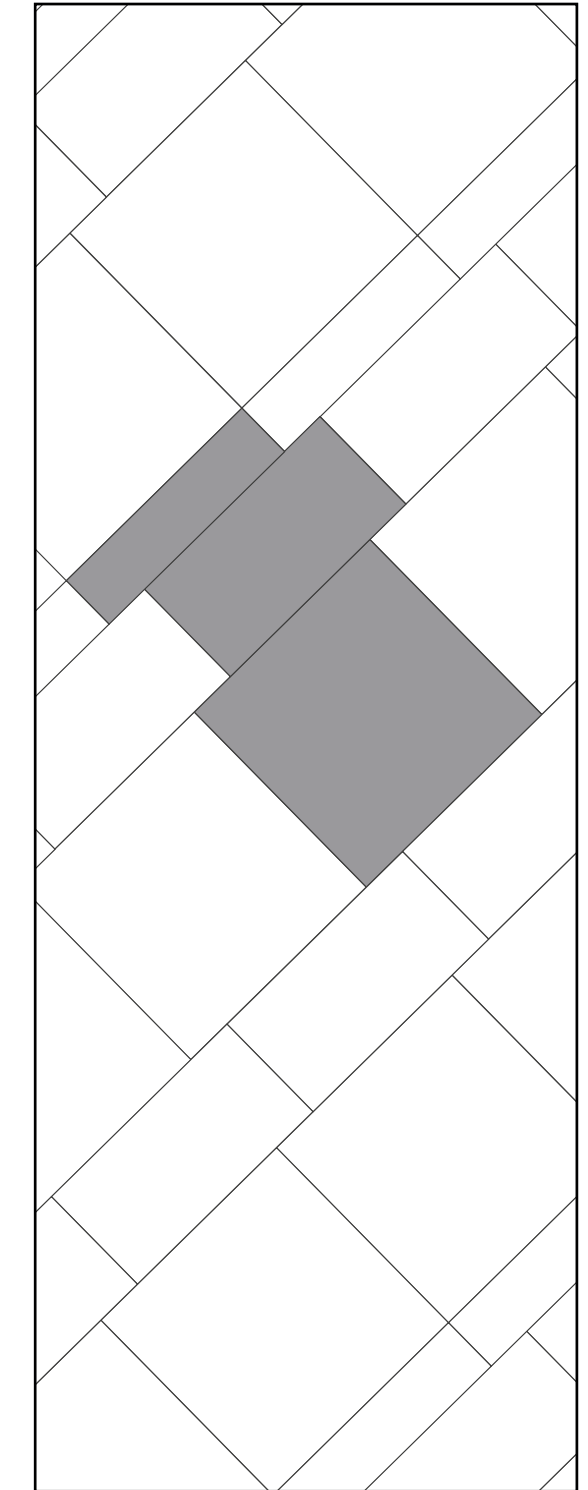

FORMATO - SIZES	%
80x80	57,14
40x80	28,57
20x80	14,28

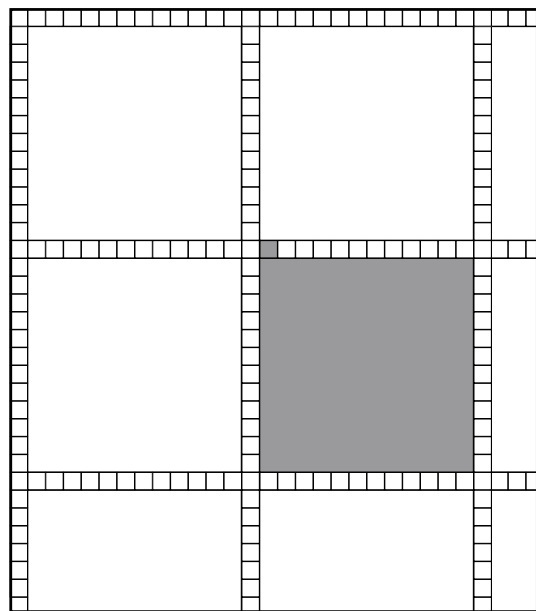

FORMATO - SIZES	%
60x60	87,70%
tozzetti 5x5	14,3%

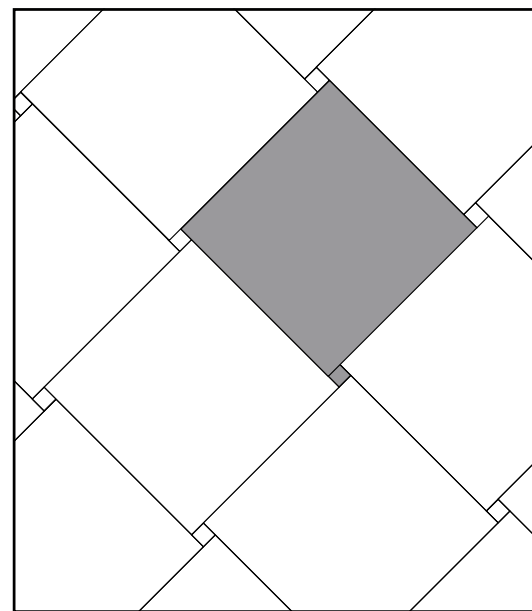

FORMATO - SIZES	%
60x60	99,3%
tozzetti 5x5	0,7%

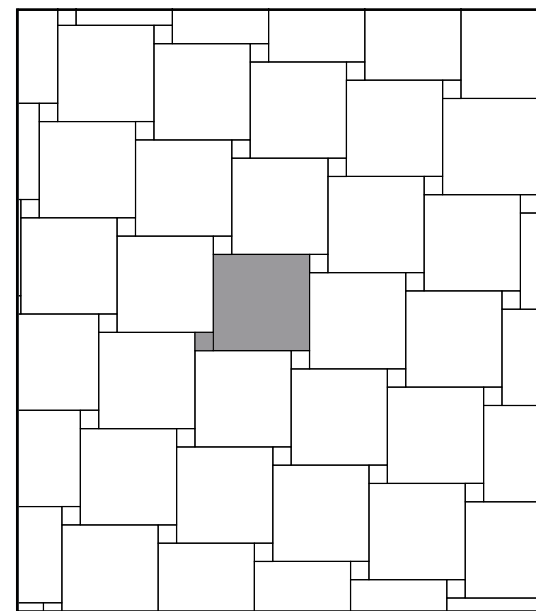



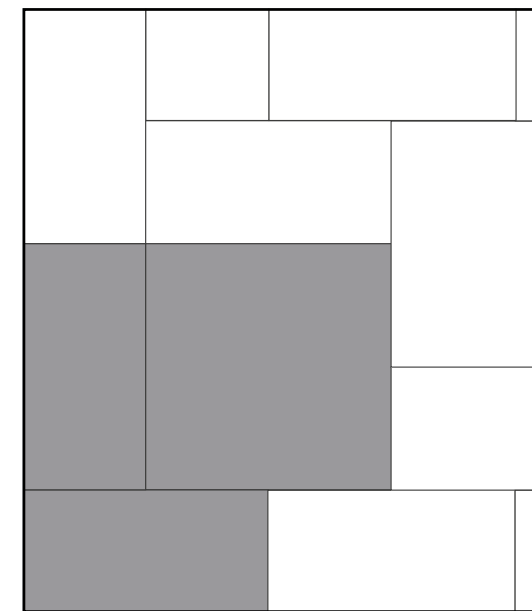



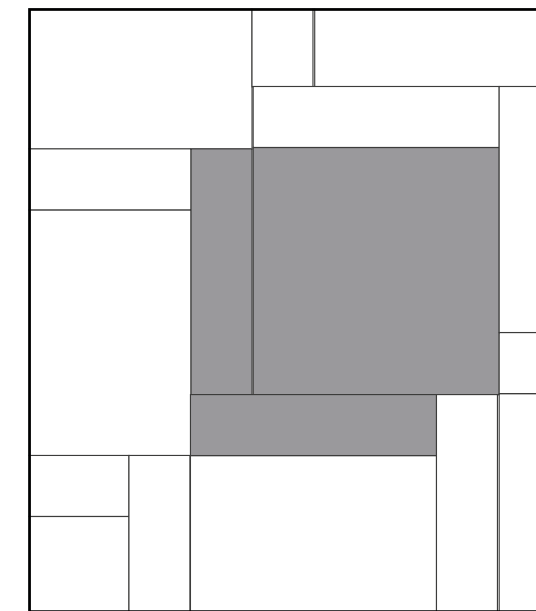







FORMATO - SIZES	%
30x30	83,3
6x6	16,7

















FORMATO - SIZES	%
80x80	50
40x80	50

















FORMATO - SIZES	%
80x80	66,65
20x80	33,35

 <p>CARATTERISTICHE TECNICHE TECHNICAL STANDARDS CARACTERISTIQUES TECHNIQUES TECHNISCHE EINGESCHAFTEN CARACTERÍSTICAS TÉCNICAS</p>	 <p>UNI EN 14411 Ap. G</p>	<p>NORME EUROPEE REFERENCE STANDARD NORME DI REFERENZE BEZUGSNORM NORMAS EUROPEAS</p>		<p>NORME ASTM REFERENCE STANDARD NORME DI REFERENZE BEZUGSNORM NORMAS</p>	 <p>ANSI 137.1</p>	<p>REQUISITI REQUIREMENTS CONDITIONS REQUISES VORAUSSETZUNGEN REQUISITOS</p> 
<p>RESISTENZA AL GELO FROST RESISTANCE RESISTANCE AU GEL FROSTBESTÄNDIGKEIT RESISTENCIA AL HIELO</p> 	<p>UNI EN ISO 10545-12</p>	<p>Richiesta Required Demande Gefordert Solicitudo</p>	<p>Resiste Resists Résiste Standhaltet Resiste</p>	<p>C1026</p>	<p>-</p>	<p>Resiste Resists Résiste Standhaltet Resiste</p>
<p>ASSORBIMENTO D'ACQUA WATER ABSORPTION ABSORPTION D'EAU WASSERAUFNAHME ABSORCIÓN DE AGUA</p> 	<p>UNI EN ISO 10545-3</p>	<p>≤ 0,5%</p>	<p>≤ 0,1%</p>	<p>C373</p>	<p>≤ 0,5%</p>	<p>≤ 0,1%</p>
<p>RESISTENZA ALLA FLESSIONE BENDING STRENGTH RESISTANCE À LA FLEXION BIEGEFESTIGKEIT RESISTENCIA A LA FLEXIÓN</p> 	<p>UNI EN ISO 10545-4</p>	<p>≥ 35 N/mm²</p>	<p>≥ 45 N/mm²</p>	<p>C648</p>	<p>≥ 250 Lbs</p>	<p>≥ 300 Lbs</p>
<p>RESISTENZA CHIMICA CHEMICAL RESISTANCE RESISTANCE CHIMIQUE CHEMIKALIENBESTÄNDIGKEIT RESISTENCIA QUÍMICA</p> 	<p>UNI EN ISO 10545-13</p>	<p>Resistenza a sali da piscina o additivi ad uso domestico = Classe GB minimo Resistance to swimming pool salts or additives for domestic use = class GB minimum Résistance au sel de piscine ou additif domestique = classe GB minimum Resistent gegen Salze in Schwimmbäder sowie im Haushaltsgebrauch = Klasse Minimum GB Resistencia a las sales de piscina o a los aditivos para utilización doméstica = clase G.B. mínimo</p> <p>Resistenza ad acidi e basi a bassa concentrazione = Dichiarato dal fabbricante Resistance to acid and bases with low concentration = declared by the manufacturer Résistance aux acides et bases à basses concentrations = Déclaré par le fabricant Niedrig konzentrierte Säure und Basen beständigkeit, Herstellerklärung Resistencia a los ácidos y a las bases de baja concentración = declarado por el productor</p> <p>Resistenza ad acidi e basi ad alta concentrazione = Metodo di prova disponibile Resistance to acids and bases with high concentration = test method available Résistance aux acides et bases à hautes concentrations = méthode de preuve disponible Hoch konzentrierte Säure und Basen beständigkeit, Prüfzeugnis Verfügbar Resistencia a los ácidos y a las bases de alta concentración = método de prueba disponible</p>	<p>Resiste Resists Résiste Standhaltet Resiste</p>	<p>C650</p>	<p>-</p>	<p>Resiste Resists Résiste Standhaltet Resiste</p>
<p>DUREZZA SUPERFICIALE (SCALA MOHS) MOHS' HARDNESS DURETÉ SUPERFICIELLE À LA RAURE RITZHÄRTE DER OBERFLÄCHE DUREZA SUPERFICIAL (ESCALA MOHS)</p> 	<p>CTI - 81-7</p>	<p>-</p>	<p>≥ 5</p>	<p>CTI - 81-7</p>	<p>-</p>	<p>≥ 5</p>
<p>DILATAZIONE TERMICA LINEARE LINEAR THERMAL EXPANSION DILATATION THERMIQUE LINEAIRE LINEARE THERMISCHE AUSDEHNUNG DILATACIÓN TÉRMICA LINEAL</p> 	<p>UNI EN ISO 10545-8</p>	<p>-</p>	<p>≥ 9Mk¹</p>	<p>C372</p>	<p>-</p>	<p>-</p>
<p>RESISTENZA AL CAVILLO RESISTANT TO CRAZING RESISTANCE À LA CRAQUELURE HAARRISSBESTÄNDIGKEIT RESISTENCIA A LAS GRIETAS</p> 	<p>UNI EN ISO 10545-11</p>	<p>Richiesta Required Demande Gefordert Solicitudo</p>	<p>Resiste Resists Résiste Standhaltet Resiste</p>	<p>C424</p>	<p>Richiesta Required Demande Gefordert Solicitudo</p>	<p>Resiste Resists Résiste Standhaltet Resiste</p>
<p>RESISTENZA AGLI SBALZI TERMICI RESISTANT TO THERMAL SHOCKS RÉSISTANCE AUX ÉCARTS DE TEMPÉRATURE THERMOSCHOCKBESTÄNDIGKEIT RESISTENCIA A LOS CAMBIOS BRUSCOS DE TEMPERATURA</p> 	<p>UNI EN ISO 10545-9</p>	<p>-</p>	<p>Resiste Resists Résiste Standhaltet Resiste</p>	<p>C484</p>	<p>Richiesta Required Demande Gefordert Solicitudo</p>	<p>Resiste Resists Résiste Standhaltet Resiste</p>
<p>RESISTENZA ALLE MACCHIE RESISTANT TO STAINING RESISTANCE AUX TACHES FLECKENBESTÄNDIGKEIT RESISTENCIA A LAS MANCHAS</p> 	<p>UNI EN ISO 10545-14</p>	<p>≥ 3</p>	<p>≥ 4</p>	<p>C1378</p>	<p>-</p>	<p>-</p>
<p>RESISTENZA ALL'ABRASIONE SUPERFICIALE PEI RESISTANCE TO DEEP ABRASION RESISTANCE A L'ABRASION PROFONDE WIDERSTAND GEGEN TIEFENVERSCHLEISS RESISTENCIA A LA ABRASIÓN PROFUNDA</p> 	<p>UNI EN ISO 10545-7</p>	<p>Classi da 0 a 5 come dichiarato dal fabbricante Classes from 0 to 5 as stated by the manufacturer. Classes de 0 à 5 conformément à la déclaration du fabricant. Klassen 0 bis 5 wie vom Hersteller angegeben. Clases de 0 a 5 como declarado por el fabricante.</p>	<p>Valore a seconda del colore prodotto. Value according to pro aduct colour. Valeur suivant la couleur du produit. Wert nach der Produktfarbe. Valor según el color del producto.</p>	<p>C1027</p>	<p>Come indicato As reported. Comme indiqué ci dessus. Wie erwähnt. Como indicado.</p>	<p>Valore a seconda del colore prodotto. Value according to pro aduct colour. Valeur suivant la couleur du produit. Wert nach der Produktfarbe. Valor según el color del producto.</p>















Vista l'ampia gamma di prodotti i valori sopra riportati sono la media della gamma produttiva
Because the selection of products is very wide, the figures given above are the average for the product range - Etant donné la vaste gamme de produits les valeurs rapportées sont la moyenne de la gamme de production.
Angesichts des großen Produktangebots sind die oben wiedergegebenen Werte Durchschnittswerte, die sich auf die gesamte Produktion beziehen. - Dada la amplia gama de productos, los valores anteriormente mencionados son la media de la gama productiva.

 <p>CARATTERISTICHE TECNICHE TECHNICAL STANDARDS CARACTERISTIQUES TECHNIQUES TECHNISCHE EINGESCHAFTEN CARACTERÍSTICAS TÉCNICAS</p>	 <p>UNI EN 14411 Ap. G</p>	<p>NORME EUROPEE REFERENCE STANDARD NORME DI REFERENZE BEZUGSNORM NORMAS EUROPEAS</p>		<p>NORME ASTM REFERENCE STANDARD NORME DI REFERENZE BEZUGSNORM NORMAS</p>	 <p>ANSI 137.1</p>	<p>REQUISITI REQUIREMENTS CONDITIONS REQUISES VORAUSSETZUNGEN REQUISITOS</p> 
<p>RESISTENZA AL GELO FROST RESISTANCE RESISTANCE AU GEL FROSTBESTÄNDIGKEIT RESISTENCIA AL HIELO</p> 	<p>UNI EN ISO 10545-12</p>	<p>Richiesta Required Demande Gefordert Solicitudo</p>	<p>Resiste Resists Résiste Standhaltet Resiste</p>	<p>C1026</p>	<p>-</p>	<p>Resiste Resists Résiste Standhaltet Resiste</p>
<p>ASSORBIMENTO D'ACQUA WATER ABSORPTION ABSORPTION D'EAU WASSERAUFNAHME ABSORCIÓN DE AGUA</p> 	<p>UNI EN ISO 10545-3</p>	<p>≤ 0,5%</p>	<p>≤ 0,1%</p>	<p>C373</p>	<p>≤ 0,5%</p>	<p>≤ 0,1%</p>
<p>RESISTENZA ALLA FLESSIONE BENDING STRENGTH RESISTANCE À LA FLEXION BIEGEFESTIGKEIT RESISTENCIA A LA FLEXIÓN</p> 	<p>UNI EN ISO 10545-4</p>	<p>≥ 35 N/mm²</p>	<p>≥ 45 N/mm²</p>	<p>C648</p>	<p>≥ 250 Lbs</p>	<p>≥ 300 Lbs</p>
<p>RESISTENZA CHIMICA CHEMICAL RESISTANCE RESISTANCE CHIMIQUE CHEMIKALIENBESTÄNDIGKEIT RESISTENCIA QUÍMICA</p> 	<p>UNI EN ISO 10545-13</p>	<p>Resistenza a sali da piscina o additivi ad uso domestico = Classe GB minimo Resistance to swimming pool salts or additives for domestic use = class GB minimum Résistance au sel de piscine ou additif domestique = classe GB minimum Resistent gegen Salze in Schwimmbäder sowie im Haushaltsgebrauch = Klasse Minimum GB Resistencia a las sales de piscina o a los aditivos para utilización doméstica = clase G.B. mínimo</p> <p>Resistenza ad acidi e basi a bassa concentrazione = Dichiarato dal fabbricante Resistance to acid and bases with low concentration = declared by the manufacturer Résistance aux acides et bases à basses concentrations = Déclaré par le fabricant Niedrig konzentrierte Säure und Basen beständigkeit, Herstellerklärung Resistencia a los ácidos y a las bases de baja concentración = declarado por el productor</p> <p>Resistenza ad acidi e basi ad alta concentrazione = Metodo di prova disponibile Resistance to acids and bases with high concentration = test method available Résistance aux acides et bases à hautes concentrations = méthode de preuve disponible Hoch konzentrierte Säure und Basen beständigkeit, Prüfzeugnis Verfügbar Resistencia a los ácidos y a las bases de alta concentración = método de prueba disponible</p>	<p>Resiste Resists Résiste Standhaltet Resiste</p>	<p>C650</p>	<p>-</p>	<p>Resiste Resists Résiste Standhaltet Resiste</p>
<p>DUREZZA SUPERFICIALE (SCALA MOHS) MOHS' HARDNESS DURETÉ SUPERFICIELLE À LA RAURE RITZHÄRTE DER OBERFLÄCHE DUREZA SUPERFICIAL (ESCALA MOHS)</p> 	<p>CTI - 81-7</p>	<p>-</p>	<p>≥ 5</p>	<p>CTI - 81-7</p>	<p>-</p>	<p>≥ 5</p>
<p>DILATAZIONE TERMICA LINEARE LINEAR THERMAL EXPANSION DILATATION THERMIQUE LINEAIRE LINEARE THERMISCHE AUSDEHNUNG DILATACIÓN TÉRMICA LINEAL</p> 	<p>UNI EN ISO 10545-8</p>	<p>-</p>	<p>≥ 9Mk¹</p>	<p>C372</p>	<p>-</p>	<p>-</p>
<p>RESISTENZA AL CAVILLO RESISTANT TO CRAZING RESISTANCE À LA CRAQUELURE HAARRISSBESTÄNDIGKEIT RESISTENCIA A LAS GRIETAS</p> 	<p>UNI EN ISO 10545-11</p>	<p>Richiesta Required Demande Gefordert Solicitudo</p>	<p>Resiste Resists Résiste Standhaltet Resiste</p>	<p>C424</p>	<p>Richiesta Required Demande Gefordert Solicitudo</p>	<p>Resiste Resists Résiste Standhaltet Resiste</p>
<p>RESISTENZA AGLI SBALZI TERMICI RESISTANT TO THERMAL SHOCKS RÉSISTANCE AUX ÉCARTS DE TEMPÉRATURE THERMOSCHOCKBESTÄNDIGKEIT RESISTENCIA A LOS CAMBIOS BRUSCOS DE TEMPERATURA</p> 	<p>UNI EN ISO 10545-9</p>	<p>-</p>	<p>Resiste Resists Résiste Standhaltet Resiste</p>	<p>C484</p>	<p>Richiesta Required Demande Gefordert Solicitudo</p>	<p>Resiste Resists Résiste Standhaltet Resiste</p>
<p>RESISTENZA ALLE MACCHIE RESISTANT TO STAINING RESISTANCE AUX TACHES FLECKENBESTÄNDIGKEIT RESISTENCIA A LAS MANCHAS</p> 	<p>UNI EN ISO 10545-14</p>	<p>≥ 3</p>	<p>≥ 4</p>	<p>C1378</p>	<p>-</p>	<p>-</p>
<p>RESISTENZA ALL'ABRASIONE SUPERFICIALE PEI RESISTANCE TO DEEP ABRASION RESISTANCE A L'ABRASION PROFONDE WIDERSTAND GEGEN TIEFENVERSCHLEISS RESISTENCIA A LA ABRASIÓN PROFUNDA</p> 	<p>UNI EN ISO 10545-7</p>	<p>Classi da 0 a 5 come dichiarato dal fabbricante Classes from 0 to 5 as stated by the manufacturer. Classes de 0 à 5 conformément à la déclaration du fabricant. Klassen 0 bis 5 wie vom Hersteller angegeben. Clases de 0 a 5 como declarado por el fabricante.</p>	<p>Valore a seconda del colore prodotto. Value according to pro aduct colour. Valeur suivant la couleur du produit. Wert nach der Produktfarbe. Valor según el color del producto.</p>	<p>C1027</p>	<p>Come indicato As reported. Comme indiqué ci dessus. Wie erwähnt. Como indicado.</p>	<p>Valore a seconda del colore prodotto. Value according to pro aduct colour. Valeur suivant la couleur du produit. Wert nach der Produktfarbe. Valor según el color del producto.</p>

Vista l'ampia gamma di prodotti i valori sopra riportati sono la media della gamma produttiva
Because the selection of products is very wide, the figures given above are the average for the product range - Etant donné la vaste gamme de produits les valeurs rapportées sont la moyenne de la gamme de production.
Angesichts des großen Produktangebots sind die oben wiedergegebenen Werte Durchschnittswerte, die sich auf die gesamte Produktion beziehen. - Dada la amplia gama de productos, los valores anteriormente mencionados son la media de la gama productiva.

 <p>CARATTERISTICHE TECNICHE TECHNICAL STANDARDS CHARACTERISTIQUES TECHNIQUES TECHNISCHE EINGESCHAFTEN CARACTERÍSTICAS TÉCNICAS</p>	<p>NORME EUROPEE REFERENCE STANDARD NORME DI RIFERENZA BEZUGSNORM NORMAS EUROPEAS</p>	 <p>UNI EN 14411 Ap. G</p> <p>REQUISITI REQUIREMENTS CONDITIONS REQUISES VORAUSSETZUNGEN REQUISITOS</p>		<p>NORME ASTM REFERENCE STANDARD NORME DI RIFERENZA BEZUGSNORM NORMAS</p>	 <p>ANSI 137.1</p> <p>REQUISITI REQUIREMENTS CONDITIONS REQUISES VORAUSSETZUNGEN REQUISITOS</p>	
RESISTENZA AL GELO <i>FROST RESISTANCE RESISTANCE AU GEL FROSTBESTÄNDIGKEIT RESISTENCIA AL HIELO</i>		UNI EN ISO 10545-12	Richiesta <i>Required Demande Gefordert Solicitud</i>	Resiste <i>Resists Résiste Standhallet Resiste</i>	C1026	Resiste <i>Resists Résiste Standhallet Resiste</i>
ASSORBIMENTO D'ACQUA <i>WATER ABSORPTION ABSORPTION D'EAU WASSERAUFNAHME ABSORCIÓN DE AGUA</i>		UNI EN ISO 10545-3	≤ 0,5%	≤ 0,1%	C373	≤ 0,5%
RESISTENZA ALLA FLESSIONE <i>BENDING STRENGTH RESISTANCE À LA FLEXION BIEGEFESTIGKEIT RESISTENCIA A LA FLEXIÓN</i>		UNI EN ISO 10545-4	≥ 35 N/mm ²	≥ 45 N/mm ²	C648	≥ 250 Lbs
RESISTENZA CHIMICA <i>CHEMICAL RESISTANCE RESISTANCE CHIMIQUE CHEMIKALBESTÄNDIGKEIT RESISTENCIA QUÍMICA</i>		UNI EN ISO 10545-13	Resistenza a sali da piscina o additivi ad uso domestico = Classe GB minimo <i>Resistance to swimming pool salts or additives for domestic use – class GB minimum. Résistance au sel de piscine ou additif domestique – classe GB minimum. Resistent gegen Salze im Schwimmbäder sowie im Haushaltgebrauch = Klasse Minimum GB. Resistencia a los sales de piscina o a los aditivos para utilización doméstica = clase G.B. mínimo.</i>	Resiste <i>Resists Résiste Standhallet Resiste</i>	-	Resiste <i>Resists Résiste Standhallet Resiste</i>
			Resistenza ad acidi e basi a bassa concentrazione = Dichiarato dal fabbricante <i>Resistance to acid and bases with low concentration – declared by the manufacturer. Résistance aux acides et bases à basses concentration = Déclaration du fabricant. Niedrig konzentrierte Säure und Basen beständigkeit, Herstellerklärung. Resistencia a los ácidos y a las bases de baja concentración = declarado por el productor</i>	-	C650	-
			Resistenza ad acidi e basi ad alta concentrazione = Metodo di prova disponibile <i>Resistance to acids and bases with high concentration – test method available. Résistance aux acides et bases à hautes concentration=methodes de preuve disponible. Hoch konzentrierte Säure und Basen beständigkeit, Prüfverfahren Verfügbar. Resistencia a los ácidos y a las bases de alta concentración = método de prueba disponible</i>	-	-	-
DUREZZA SUPERFICIALE (SCALA MOHS) <i>MOHS' HARDNESS DURETÉ SUPERFICIELLE À LA RAYURE RITZHÄRTE DER OBERFLÄCHE DUREZA SUPERFICIAL (ESCALA MOHS)</i>		CTI - 81-7	-	≥ 6	CTI - 81-7	≥ 6
RESISTENZA ALL'ABRASIONE PROFONDA <i>RESISTANCE TO DEEP ABRASION RESISTANCE A L'ABRASION PROFONDE WIDERSTAND GEGEN TIEFENVERSCHLEISS RESISTENCIA A LA ABRASIÓN PROFUNDA</i>		UNI EN ISO 10545-6	≤ 175 mm ³	< 150 mm ³	C1243	< 175 mm ³
RESISTENZA ALLE MACCHIE <i>RESISTANT TO STAINING RESISTANCE AUX TACHES FLECKENBESTÄNDIGKEIT RESISTENCIA A LAS MANCHAS</i>		UNI EN ISO 10545-14	-	≥ 4	C1378	-
DILATAZIONE TERMICA LINEARE <i>LINEAR THERMAL EXPANSION DILATATION THERMIQUE LINEAIRE LINEARE THERMISCHE AUSDEHNUNG DILATACIÓN TÉRMICA LINEAL</i>		UNI EN ISO 10545-8	-	≥ 9Mk ¹	C372	-
RESISTENZA AGLI SBALZI TERMICI <i>RESISTANT TO THERMAL SHOCKS RESISTANCE AUX ÉCARTS DE TEMPÉRATURE THERMOSCHOCKBESTÄNDIGKEIT RESISTENCIA A LOS CAMBIOS BRUSCOS DE TEMPERATURA</i>		UNI EN ISO 10545-9	-	Resiste <i>Resists Résiste Standhallet Resiste</i>	C484	Richiesta <i>Required Demande Gefordert Solicitud</i>

Vista l'ampia gamma di prodotti i valori sopra riportati sono la media della gamma produttiva
*Because the selection of products is very wide, the figures given above are the average for the product range - Etant donné la vaste gamme de produits les valeurs rapportées sont la moyenne de la gamme de production.
 Angesichts des großen Produktangebots sind die oben wiedergegebenen Werte Durchschnittswerte, die sich auf die gesamte Produktion beziehen - Dada la amplia gama de productos, los valores anteriormente mencionados son la media de la gama productiva.*

 <p>CARATTERISTICHE TECNICHE TECHNICAL STANDARDS CHARACTERISTIQUES TECHNIQUES TECHNISCHE EINGESCHAFTEN CARACTERÍSTICAS TÉCNICAS</p>	<p>NORME EUROPEE REFERENCE STANDARD NORME DI RIFERENZA BEZUGSNORM NORMAS EUROPEAS</p>	 <p>UNI EN 14411 Ap. K Gruppo B III</p> <p>REQUISITI REQUIREMENTS CONDITIONS REQUISES VORAUSSETZUNGEN REQUISITOS</p>		<p>NORME ASTM REFERENCE STANDARD NORME DI RIFERENZA BEZUGSNORM NORMAS</p>	 <p>ANSI 137.1</p> <p>REQUISITI REQUIREMENTS CONDITIONS REQUISES VORAUSSETZUNGEN REQUISITOS</p>	
RESISTENZA AL GELO <i>FROST RESISTANCE RESISTANCE AU GEL FROSTBESTÄNDIGKEIT RESISTENCIA AL HIELO</i>		Applicabile	-	ASTM C 1026	Come indicato <i>As reported Comme indiqué ci dessus. Wie erwähnt Como indicado.</i>	-
ASSORBIMENTO D'ACQUA <i>WATER ABSORPTION ABSORPTION D'EAU WASSERAUFNAHME ABSORCIÓN DE AGUA</i>		≥ 10% medio	≥ 15%	ASTM C 373	7% < Ass H ₂ O ≤20%	-
RESISTENZA ALLA FLESSIONE <i>BENDING STRENGTH RESISTANCE À LA FLEXION BIEGEFESTIGKEIT RESISTENCIA A LA FLEXIÓN</i>		≥ 12N/mm ² sp ≥ 7,5	> 18	ASTM C 648	≥ 125 Lbf Val. singolo ≥ 100 Lbf	≥ 125 Lbf
DUREZZA SUPERFICIALE (SCALA MOHS) <i>MOHS' HARDNESS DURETÉ SUPERFICIELLE À LA RAYURE RITZHÄRTE DER OBERFLÄCHE DUREZA SUPERFICIAL (ESCALA MOHS)</i>		-	-	CTI - 81-7	-	-
DILATAZIONE TERMICA LINEARE <i>LINEAR THERMAL EXPANSION DILATATION THERMIQUE LINEAIRE LINEARE THERMISCHE AUSDEHNUNG DILATACIÓN TÉRMICA LINEAL</i>		Applicabile	-	ASTM C 372	-	-
RESISTENZA AL CAVILLO <i>RESISTANT TO CRAZING RESISTANCE À LA CRAQUELURE HAARRISSBESTÄNDIGKEIT RESISTENCIA A LAS GRIETAS</i>		Richiesta <i>Required Demande Gefordert Solicitud</i>	Resiste <i>Resists Résiste Standhallet Resiste</i>	ASTM C 424	Richiesta <i>Required Demande Gefordert Solicitud</i>	Resiste <i>Resists Résiste Standhallet Resiste</i>
RESISTENZA AGLI SBALZI TERMICI <i>RESISTANT TO THERMAL SHOCKS RESISTANCE AUX ÉCARTS DE TEMPÉRATURE THERMOSCHOCKBESTÄNDIGKEIT RESISTENCIA A LOS CAMBIOS BRUSCOS DE TEMPERATURA</i>		Applicabile	Resiste <i>Resists Résiste Standhallet Resiste</i>	ASTM C 484	Richiesta <i>Required Demande Gefordert Solicitud</i>	Resiste <i>Resists Résiste Standhallet Resiste</i>
RESISTENZA ALLE MACCHIE <i>RESISTANT TO STAINING RESISTANCE AUX TACHES FLECKENBESTÄNDIGKEIT RESISTENCIA A LAS MANCHAS</i>		GL = min Classe 3	5	ASTM C 1378	Come indicato <i>As reported Comme indiqué ci dessous. Wie erwähnt Como indicado.</i>	-
RESISTENZA ALL'ATTACCO CHIMICO <i>RESISTANT TO CHEMICAL ATTACK RESISTANCE AUX ATTAQUES CHIMIQUES RESISTENT GEGEN CHEMIKALIEN RESISTENCIA A LOS ATAQUES QUÍMICOS</i>		Min B - House hold chemicals Applicabile - Basse concentrazioni Applicabile - Alte concentrazioni	-	ASTM C 650	Come indicato <i>As reported Comme indiqué ci dessous. Wie erwähnt Como indicado.</i>	-

Vista l'ampia gamma di prodotti i valori sopra riportati sono la media della gamma produttiva
*Because the selection of products is very wide, the figures given above are the average for the product range - Etant donné la vaste gamme de produits les valeurs rapportées sont la moyenne de la gamme de production.
 Angesichts des großen Produktangebots sind die oben wiedergegebenen Werte Durchschnittswerte, die sich auf die gesamte Produktion beziehen - Dada la amplia gama de productos, los valores anteriormente mencionados son la media de la gama productiva.*

pastorelli



Pastorelli S.p.A - Via Magazzino, 1944 - 41056 Savignano sul Panaro (MO) - ITALY
Tel. +39.059.739.111 - Fax +39.059.796.291
E-mail: info@pastorellitiles.com
www.pastorellitiles.com



Ceramics of Italy